

Transit Stop Design Guidelines

October 2025



Contents

1.0 Introduction	4	3.0 Bus Stop Design	18
1.1 Additional Resources	6	3.1 Bus Stop Placement Considerations	19
2.0 Bus Stop Improvement Process	7	Location Near Intersections	20
2.1 Design Process	8	Sight Distance.....	21
Survey	9	Connection to Accessible Pedestrian Routes	22
Bus Shelter Design	10	Proximity to Crosswalks.....	23
2.2 Permitting	11	Proximity to Driveways.....	24
Bus Stops Within VDOT Right of Way	12	Drainage.....	25
Bus Stops in Other Public Right of Way	15	3.2 Placement of Amenities	26
Bus Stops Outside of Public Right of Way	16	Clear Zone and Lateral Offset	27
		Bus Stops Adjacent to Shared-Use Paths or Bicycle Facilities	29
		3.3 Utilities	30
		3.4 Safety and Security	31
		General Considerations.....	32
		Bus Stop Lighting	33
		3.5 Landscaping	34



Contents cont'd

4.0 Passenger Amenities.....	36
4.1 Bus Stop Sign.....	37
Bus Stop Sign Design.....	38
Bus Stop Sign Placement.....	40
4.2 Boarding and Alighting Area	41
Boarding and Alighting Area Minimum Requirements.....	42
Other Alighting Areas	44
4.3 Accessible Pedestrian Routes.....	45
4.4 Shelters.....	46
Shelter Design	47
4.5 Bench Design	49
4.6 Trash Receptacles	51
4.7 Bicycle Parking	53
4.8 Lighting.....	55
4.9 Passenger Information.....	57
4.10 Pavement Adjacent to Bus Stops	59
5.0 Typical Design Strategies.....	62

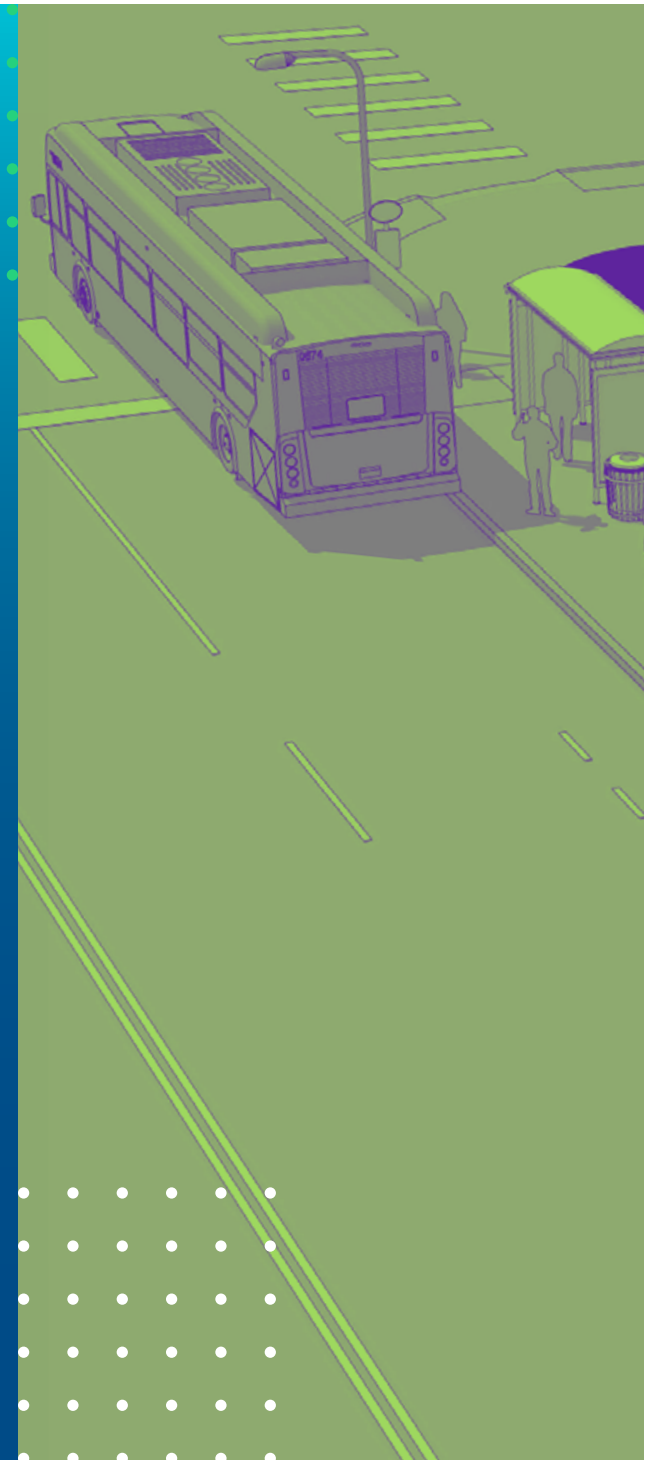
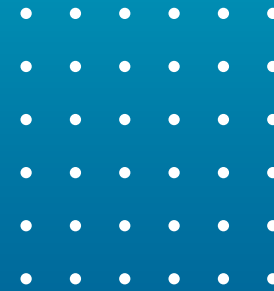

Introduction

1.0

The Virginia Department of Rail and Public Transportation (DRPT) developed these Transit Stop Design Guidelines to assist transit agencies, localities, and design professionals in the planning and design of bus stops throughout the Commonwealth.

1.0 Introduction

This document primarily addresses typical bus stop installations on public roads and streets. Bus stops located outside the public right of way, including off-street transfer centers owned or operated by transit agencies, may have different design and permitting considerations beyond what is discussed here. These guidelines do not include design aspects of bus stops intended to support level or near-level boarding, such as bus rapid transit (BRT) stations.

Rail transit stations and stops, including for street-running light rail or streetcar, are not covered in this document. For guidance related to these types of uses, designers should refer to the transit agency's design criteria, state and federal regulations, and other rail transit station design best practices.

The location, design, and permitting of bus stop improvements must comply with local, state, and federal laws and regulations. The designer should also look to established guidelines of the transit agency (or agencies) that serves the stop, and reference best practices for transit stop design.



1.0 Introduction

Additional Resources

1.1

Some best practices resources can be found in the following list. In addition to these publications, DRPT is available to support transit agencies throughout Virginia with technical guidance regarding design of bus stop improvements.

- 1 U.S. Access Board, [Accessibility Guidelines for Pedestrian Facilities in the Public Right of Way \(PROWAG\)](#) [↗](#), 41 CFR Part 102-76.
- 2 U.S. Department of Justice and U.S. Department of Transportation, [Americans with Disabilities Act \(ADA\) Accessibility Standards](#) [↗](#).
- 3 Virginia Department of Transportation (VDOT), [Road Design Manual](#) [↗](#).
- 4 National Association of City Transportation Officials (NACTO), *Transit Street Design Guide*, 2016.
- 5 American Association of State Highway and Transportation Officials (AASHTO) publications:
 - *A Policy on Geometric Design of Highways and Streets*
 - *Roadside Design Guide*
 - *Guide for Geometric Design of Transit Facilities on Highways and Streets*
- 6 Guidelines prepared by individual transit agencies:
 - Washington Metropolitan Area Transit Authority (WMATA), *Guidelines for the Design and Placement of Bus Stops*
 - Arlington County DES/DOT/Transit Bureau, *Arlington's Bus Stop Guidelines & Standards Manual*

Bus Stop Improvement Process 2.0

The steps that transit agencies must take to develop bus stops varies throughout the Commonwealth. This section discusses key aspects of this process for bus stop improvement projects, including design considerations and permitting requirements.

2.0 Bus Stop Improvement Process

Design Process

Bus stop improvement designs should be completed by a professional who is familiar with the technical requirements of these projects. The transit agency and designer should coordinate with reviewing jurisdictions to verify their requirements for documentation — many jurisdictions require plans for bus stop improvements to be sealed by a professional engineer licensed in Virginia and submitted as part of their review process.

Transit agencies may procure design services directly or collaborate with local government partners to identify available design resources.



2.0 Bus Stop Improvement Process

2.1 Design Process

Survey

As part of the design process, a topographic survey is recommended, especially when the improvements include site grading and accessible ramps and sidewalks. The survey should include **utility locations**, depending on the site conditions and local requirements. If subsurface utility engineering (SUE) is used, the designer, surveyor, and transit agency should collaborate to determine the appropriate level of information to be obtained for a given site.

Utility Locations

Utility locations can consist of Virginia 811 (formerly Miss Utility) markings or subsurface utility engineering (SUE) designations.



2.0 Bus Stop Improvement Process

2.1 Design Process

Bus Shelter Design

When proposed bus stop improvements include shelters, the designer must have structural design calculations for the shelter model. These calculations must be prepared based on the current version of the *Virginia Uniform Statewide Building Code (USBC)* using design wind speed and snow loads applicable for the location where the shelter will be installed. The calculations must be completed under the supervision of a professional engineer licensed in Virginia. They must include the professional's seal, signature, and date.

Transit agencies can obtain these calculations through the shelter manufacturer. As part of bus shelter procurements, it is recommended that transit agencies include a requirement for the manufacturer to supply structural calculations for each model to be ordered. The transit agency should describe known site constraints where shelters may be installed (e.g., areas of limited right of way), so that the engineer can prepare a design that can accommodate those situations.

The shelter structural design calculations will be used in the site design and permitting process, which are discussed later in this document.

Virginia Uniform Statewide Building Code (USBC)

The Virginia Uniform Statewide Building Code (USBC) contains the building regulations that must be complied with when constructing a new building, structure, or an addition to an existing building. They must also be used when maintaining or repairing an existing building or renovating or changing the use of a building or structure. The USBC is comprised of three parts: Virginia Construction Code, Virginia Existing Building Code and Virginia Maintenance Code.



2.0 Bus Stop Improvement Process

Permitting

Permitting requirements for bus stops will vary depending on whether the improvements are to be constructed within VDOT right of way, right of way under the jurisdiction of a local government, or on private property.

2.2



2.0 Bus Stop Improvement Process

2.2 Permitting

Bus Stops Within VDOT Right of Way

Art and Architectural Review Board (AARB)

AARB is an advisory board that reviews the design or modifications of buildings constructed on state-owned property, which includes transit shelters within VDOT right of way.

A VDOT Land Use Permit is required for any work performed along roads owned or maintained by VDOT. In order for VDOT to process a permit request, VDOT must review and approve the site plan for the bus stop that is submitted to the locality. The designer should contact the locality regarding its site plan submittal process.

When bus stop improvements include a shelter within VDOT right of way, the permitting process depends on the size of the shelter to be installed.



Bus shelters at typical bus stops will have **LESS THAN 256 SQUARE FEET** of interior shelter floor surface area. In this case, the following are required when the shelter is proposed within VDOT right of way:

- 1 Approval by the Commonwealth of Virginia **Art and Architectural Review Board (AARB)**. The transit agency should contact DRPT for assistance with the AARB submission process.
- 2 A completed VDOT *Land Use Permit Application for Small Transit Shelter* (LUP-STs). Refer to VDOT's website for detailed instructions on how to

complete the LUP-STs form. The permit application requires a signed LUP-STs form, plans to be approved by VDOT, AARB approval, surety, and insurance for each installation. There is a permit application fee for each LUP-STs instance.

- 3 The Code of Virginia designates the local building official as having jurisdiction to enforce USBC requirements for transit shelters that are less than 256 square feet. The transit agency and/or designer should coordinate with the building official in the locality where the shelter will be installed to determine their requirements for obtaining building permits and inspections.

2.0 Bus Stop Improvement Process

2.2 Permitting

Bus Stops Within VDOT Right of Way (cont'd)

>256
SQ FT

If the proposed shelter within VDOT right of way has **GREATER THAN 256 SQUARE FEET** of interior floor surface area, the transit agency and/or designer can use the LUP-STS form to initiate VDOT's review of the bus stop and shelter.

- 1 VDOT Residency permit staff will then forward the information to VDOT's Central Office Capital Outlay Facilities Management Division for review, which will increase the review time.

- 2 The Virginia Department of General Services must also review the shelter plans as the building official having jurisdiction. In this uncommon situation, the transit agency and designer should contact DRPT for further guidance.



If the proposed bus stop improvements within VDOT right of way do not include a shelter, such as construction of sidewalk, landing pads, or installation of a bench, approval from the locality and a VDOT Land Use Permit will be required. However, approval from AARB or the local building official are not required.



2.0 Bus Stop Improvement Process

2.2 Permitting

Permitting Process for Bus Stops Within VDOT Right of Way

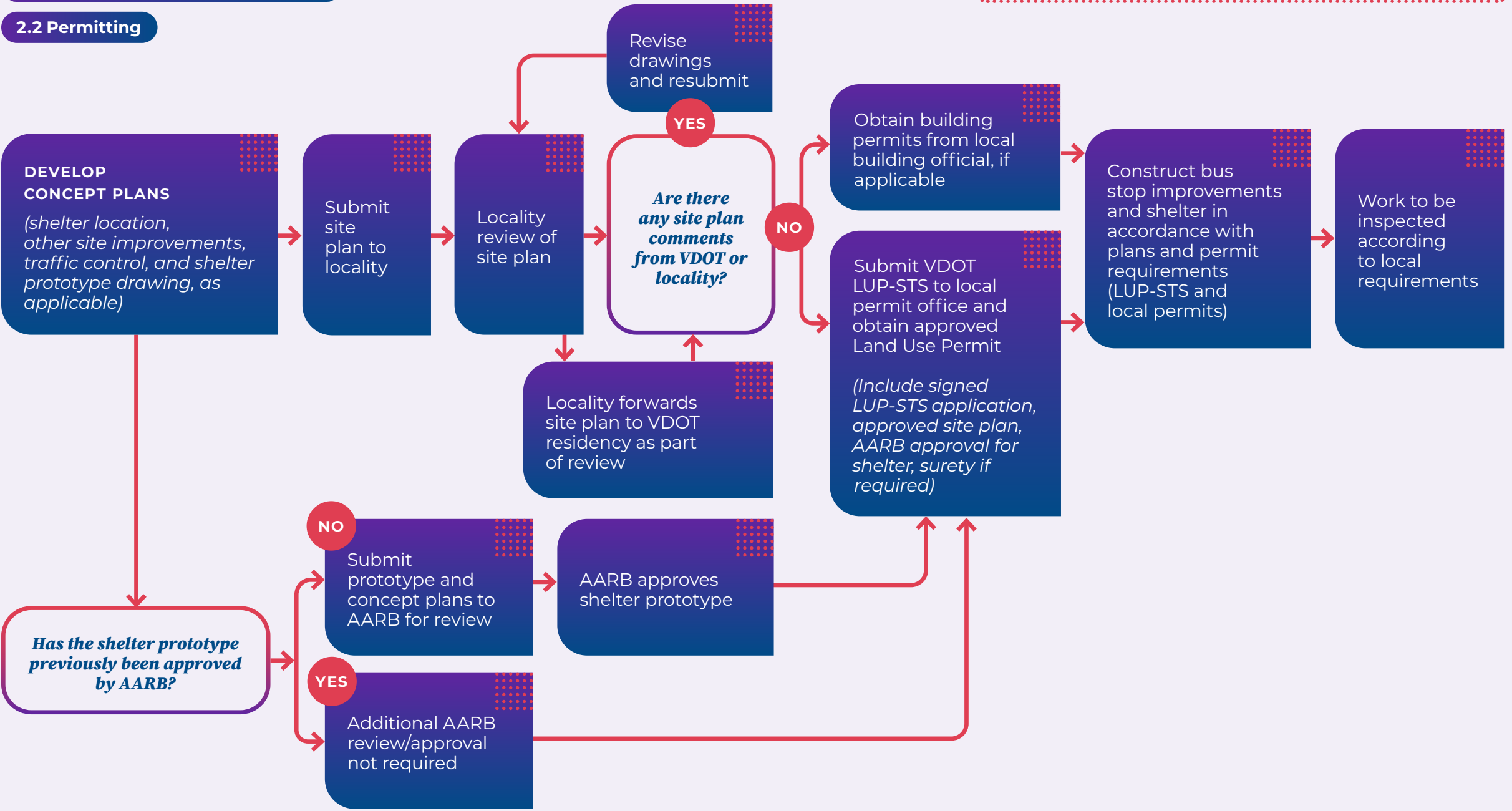

2.0 Bus Stop Improvement Process

2.2 Permitting

Bus Stops in Other Public Right of Way

When a bus stop is located within the public right of way under the jurisdiction of a local government, the locality is responsible for approving designs and permitting. Prior to starting the design of bus stop improvements, the transit agency and designer should contact the locality to identify its requirements and review process.



2.0 Bus Stop Improvement Process

2.2 Permitting

Bus Stops Outside of Public Right of Way

Bus stop improvements are sometimes located on private property outside of right of way limits, even when the bus route is on an adjacent public roadway. In this case, the locality has authority to approve designs and permitting any work outside of the right of way. The transit agency and designer should contact the locality to identify its requirements and review process.

Any work within adjacent right of way remains under the jurisdiction of the right of way owner (VDOT or locality). There may be a separate process for review and obtaining permits for the work within the right of way.



2.0 Bus Stop Improvement Process

2.2 Permitting

Permitting Process for Bus Stops Outside of VDOT Right of Way (Non-VDOT Public ROW or Private Property)

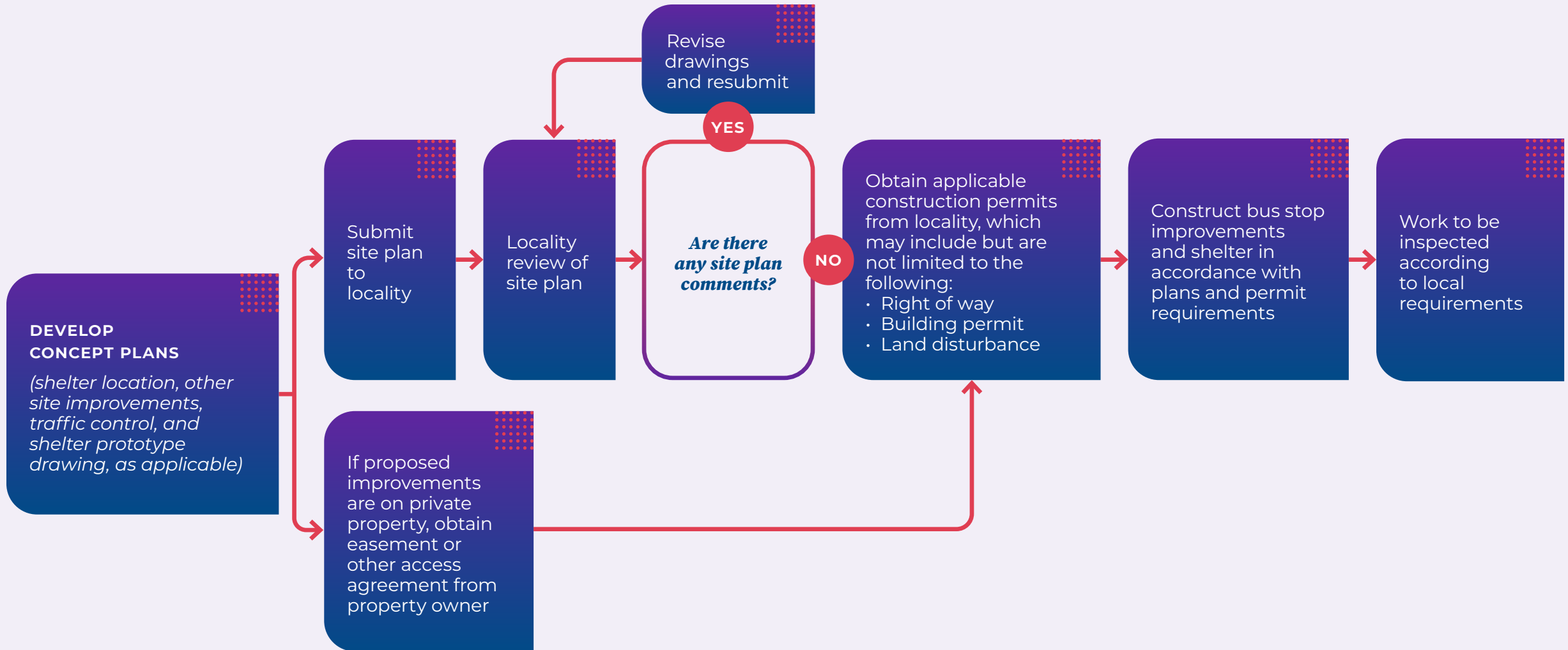

Bus Stop Design

3.0

When designing a new bus stop or improving an existing one, the transit agency and designer must consider how it relates to its surroundings. Relevant factors include pedestrian safety, roadway characteristics, and adjacent land uses. This section discusses some of the elements that may influence the placement of bus stops and passenger amenities.

3.0 Bus Stop Design

Bus Stop Placement Considerations

3.1



3.0 Bus Stop Design

3.1 Bus Stop Placement Considerations

Location Near Intersections

The location of a bus stop is determined by the transit agency in coordination with the local jurisdiction and stakeholders such as VDOT (when in VDOT right of way), transit users, or adjacent property owners. Factors that may affect bus stop placement include ridership, current and future land uses, the surrounding pedestrian environment, and safety considerations.



IN GENERAL, THERE ARE THREE OPTIONS FOR PLACING A BUS STOP NEAR INTERSECTIONS:

- 1 **FAR-SIDE:** Located after the bus crosses the intersection.
- 2 **NEAR-SIDE:** Located before the bus crosses the intersection.
- 3 **MID-BLOCK:** Located between intersections.

The far side of an intersection is generally preferred, particularly on high-volume roadways and where the bus stop includes a pullout. Because mid-block bus stops away from crosswalks tend to encourage unsafe road crossings, they are not desired except to provide service to major trip generators, or unless there is inadequate space or capacity at a nearby intersection.

Far-Side Bus Stops

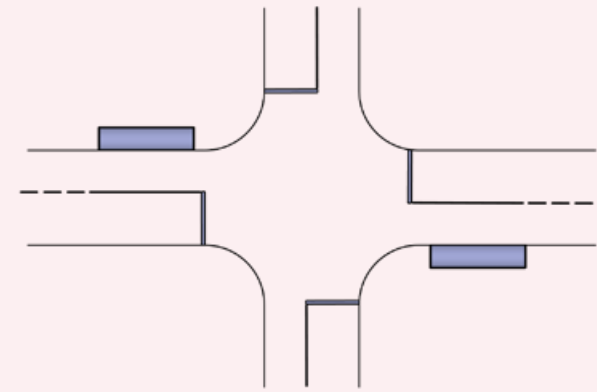

Near-Side Bus Stops

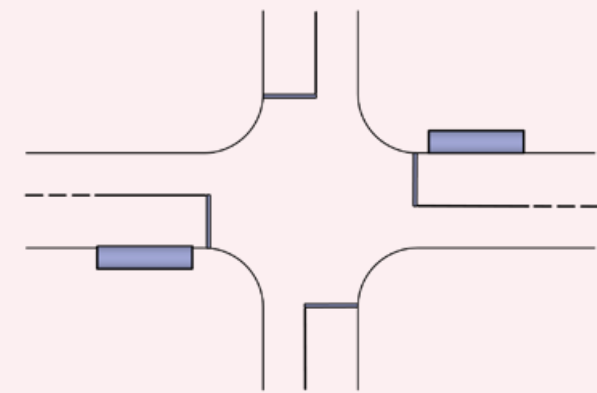

Mid-Block Bus Stops

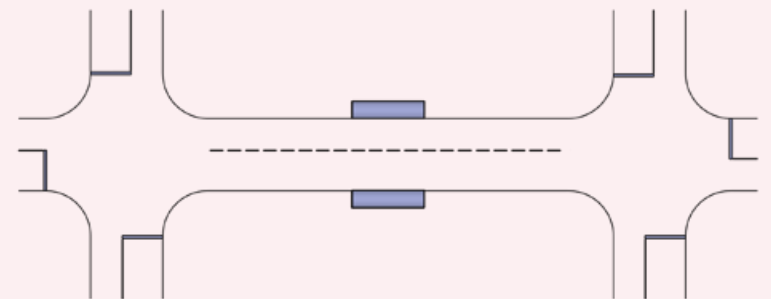

3.0 Bus Stop Design

3.1 Bus Stop Placement Considerations

Sight Distance

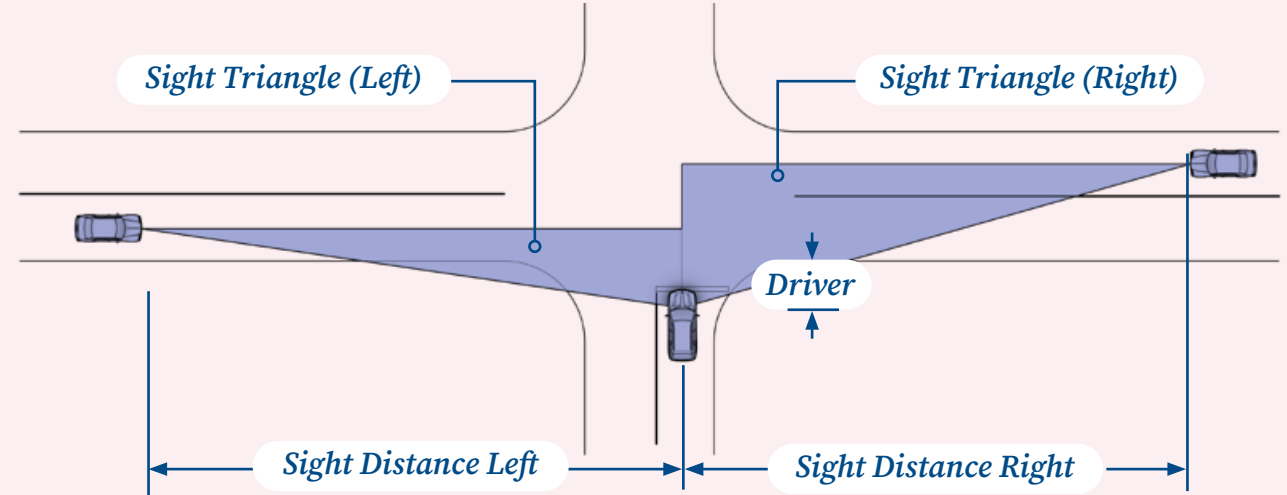

When placing bus stops, consider whether drivers can see a stopped bus in the travel lane with adequate time to react. Bus stops should not be located where minimum stopping sight distances cannot be provided for bus operators, other drivers, pedestrians, or bicyclists. Do not place bus stops where restricted sightlines exist, such as along horizontal curves or crest vertical curves.

If a bus stop must be located where there is limited sight distance, signs should be placed to warn approaching vehicles of the upcoming bus stop. A bus pullout should be considered in this situation. A bus pullout must be designed so that the bus can re-enter the travel lane safely.

Amenities at bus stops shall be placed outside of the sight triangle so that they do not obstruct visibility for drivers at nearby intersections and driveways.



For shelters on VDOT-owned or maintained roads, VDOT will evaluate sight distances as part of its permit review. Refer to the [VDOT Road Design Manual](#) (Appendix A1) and the [AASHTO Green Book \(Chapter 9\)](#) for further guidance regarding determination of sight distances. See also VDOT's [Road and Bridge Standards SD-1 through SD-5](#).

3.0 Bus Stop Design

3.1 Bus Stop Placement Considerations

Connection to Accessible Pedestrian Routes

All new bus stops shall be connected to pedestrian circulation paths that provide access to one or more destinations. To minimize the cost of constructing sidewalks, bus stops should be placed where there is an existing accessible pedestrian route, including sidewalk and curb ramps.

When improvements are made to an existing bus stop to provide amenities, the boarding and alighting area shall be connected to accessible pedestrian routes in accordance with *ADA* requirements and *PROWAG* Section R309.1.3.2. Accessible pedestrian routes shall connect boarding and alighting areas to bus shelters, benches, and other bus stop elements.

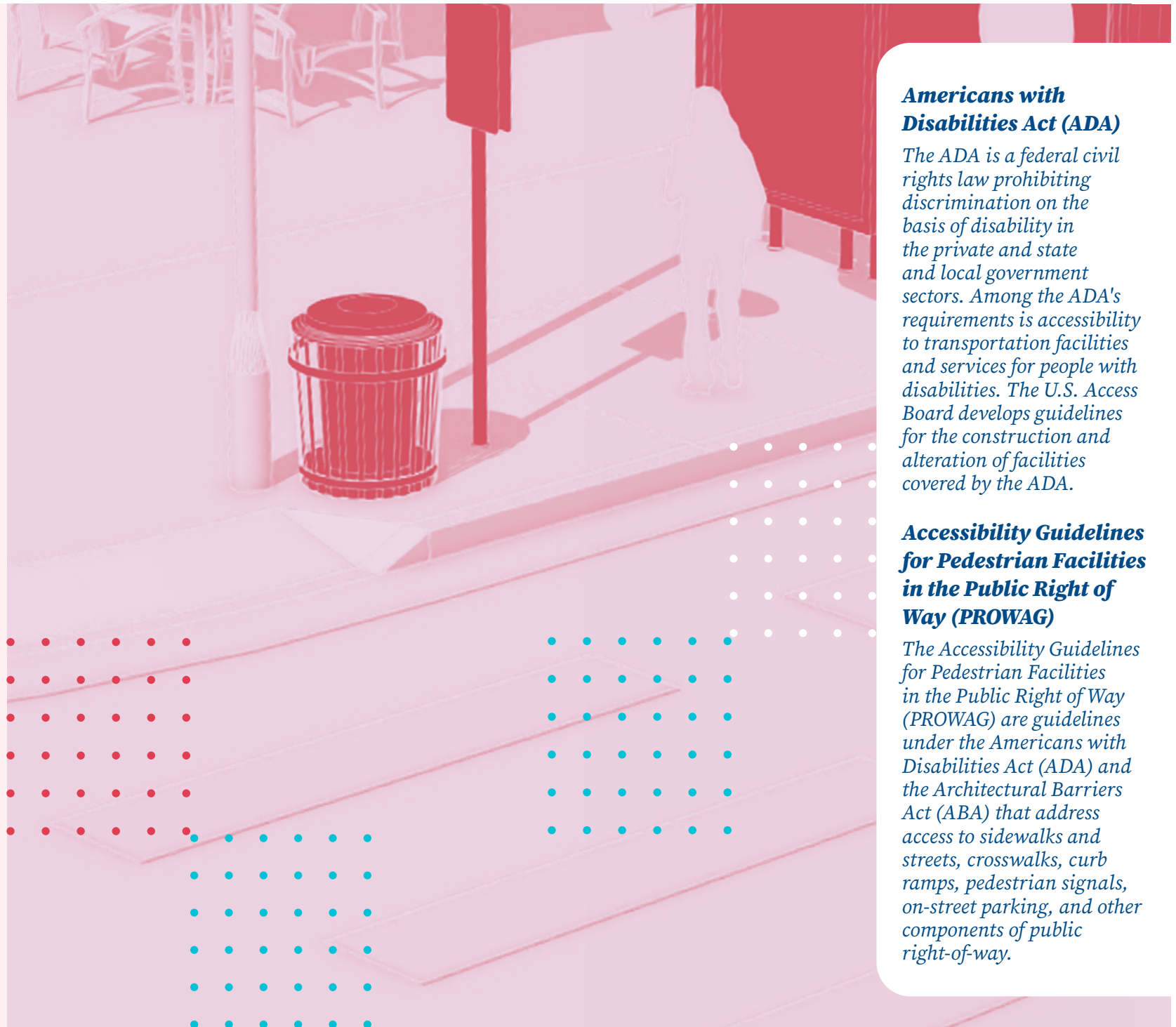

Americans with Disabilities Act (ADA)

The ADA is a federal civil rights law prohibiting discrimination on the basis of disability in the private and state and local government sectors. Among the ADA's requirements is accessibility to transportation facilities and services for people with disabilities. The U.S. Access Board develops guidelines for the construction and alteration of facilities covered by the ADA.

Accessibility Guidelines for Pedestrian Facilities in the Public Right of Way (PROWAG)

The Accessibility Guidelines for Pedestrian Facilities in the Public Right of Way (PROWAG) are guidelines under the Americans with Disabilities Act (ADA) and the Architectural Barriers Act (ABA) that address access to sidewalks and streets, crosswalks, curb ramps, pedestrian signals, on-street parking, and other components of public right-of-way.

3.0 Bus Stop Design

3.1 Bus Stop Placement Considerations

Proximity to Crosswalks

Bus stops at intersections should be located so that pedestrians can reach a crosswalk within a short distance.

THE FOLLOWING ARE RECOMMENDATIONS FOR BUS STOP PLACEMENT NEAR CROSSWALKS:



BUS STOPS should be placed so that a stopped bus does not block the crosswalk or any part of the intersection.



FOR NEAR-SIDE STOPS: locate the bus stop so that the front of the bus is at least 5 feet back from an intersection stop bar, crosswalk markings, or a stop sign.



FOR FAR-SIDE STOPS: locate the bus stop so that the rear of the bus is at least 10 feet ahead of a marked crosswalk or curb radius. If standard 40-foot buses are used, the front of the bus stop should be at least 50 feet ahead of the crosswalk or curb radius.



IF A FAR-SIDE STOP IS LOCATED IN A PARKING LANE OR BUS TURNOUT, provide additional space ahead of the stopping point for the bus to maneuver into the adjacent travel lane.

Near-side Bus Stops

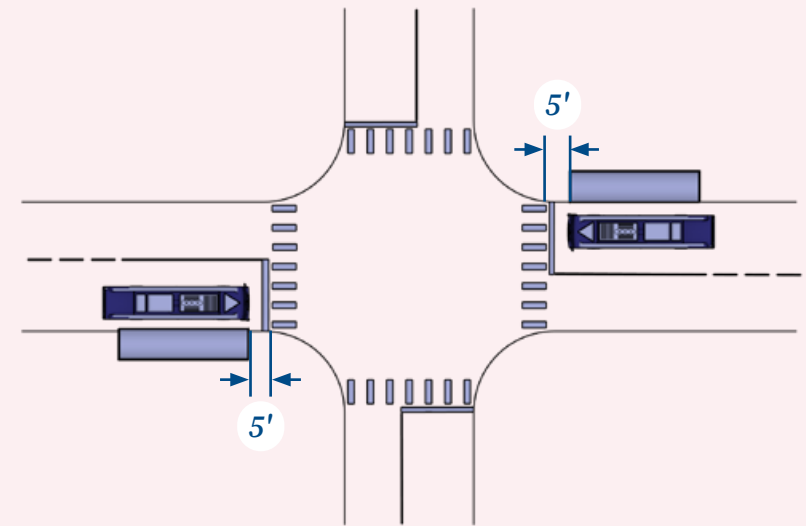

Far-side Bus Stops

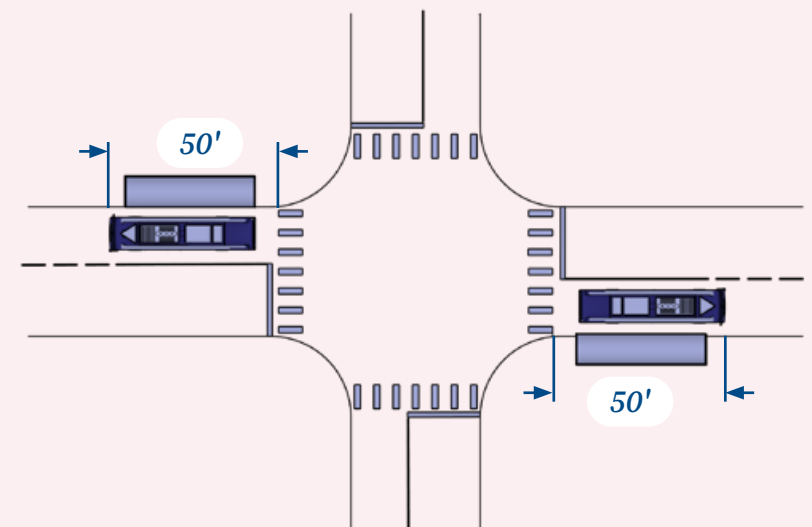

3.0 Bus Stop Design

3.1 Bus Stop Placement Considerations

Proximity to Driveways

Bus stops should be located so that driveways are not obstructed by a stopped bus. If a bus stop must be placed near a driveway, it is preferred to be located on the far side of the driveway. Where there are multiple driveways serving a parcel on the same street, it is better to block the downstream driveway so that vehicles can turn behind the bus to access the property. Bus stop design should prevent vehicles from squeezing past a bus into an area with reduced sight distance.

Bus Stop on Far Side of Driveway

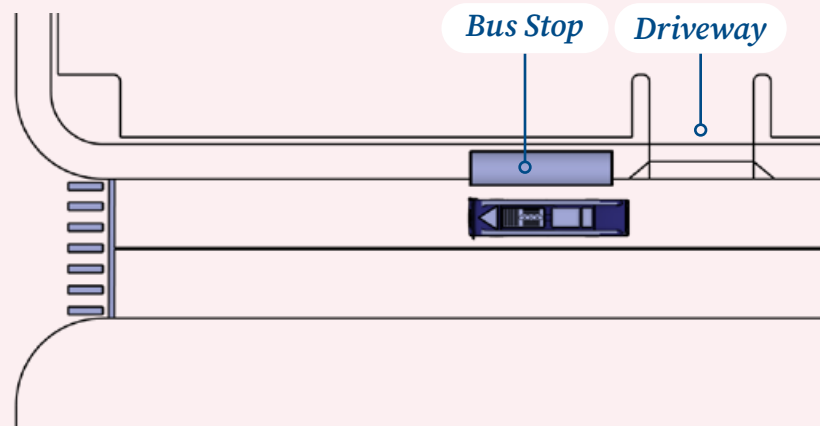

Bus Stop Near Multiple Driveways Serving the Same Parcel

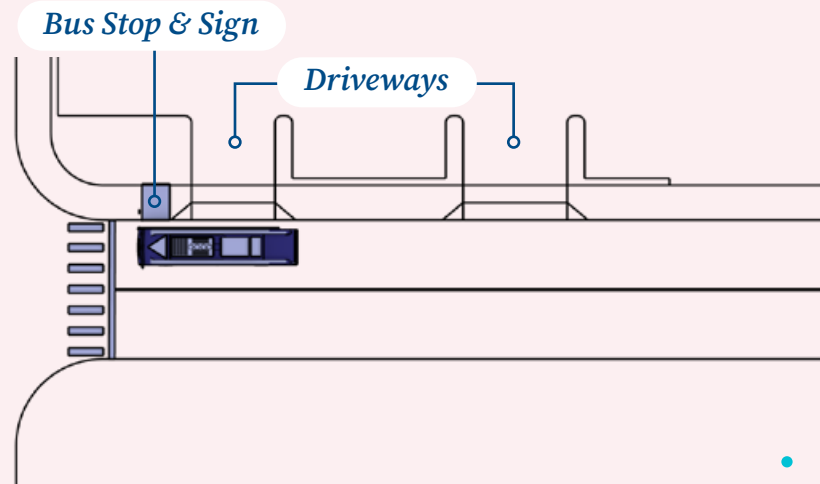

3.0 Bus Stop Design

3.1 Bus Stop Placement Considerations

Drainage

Bus stop sites should be designed so that water drains away from waiting passengers and boarding areas. Boarding and alighting areas should be avoided near drainage low points and areas where water tends to collect along the roadway.

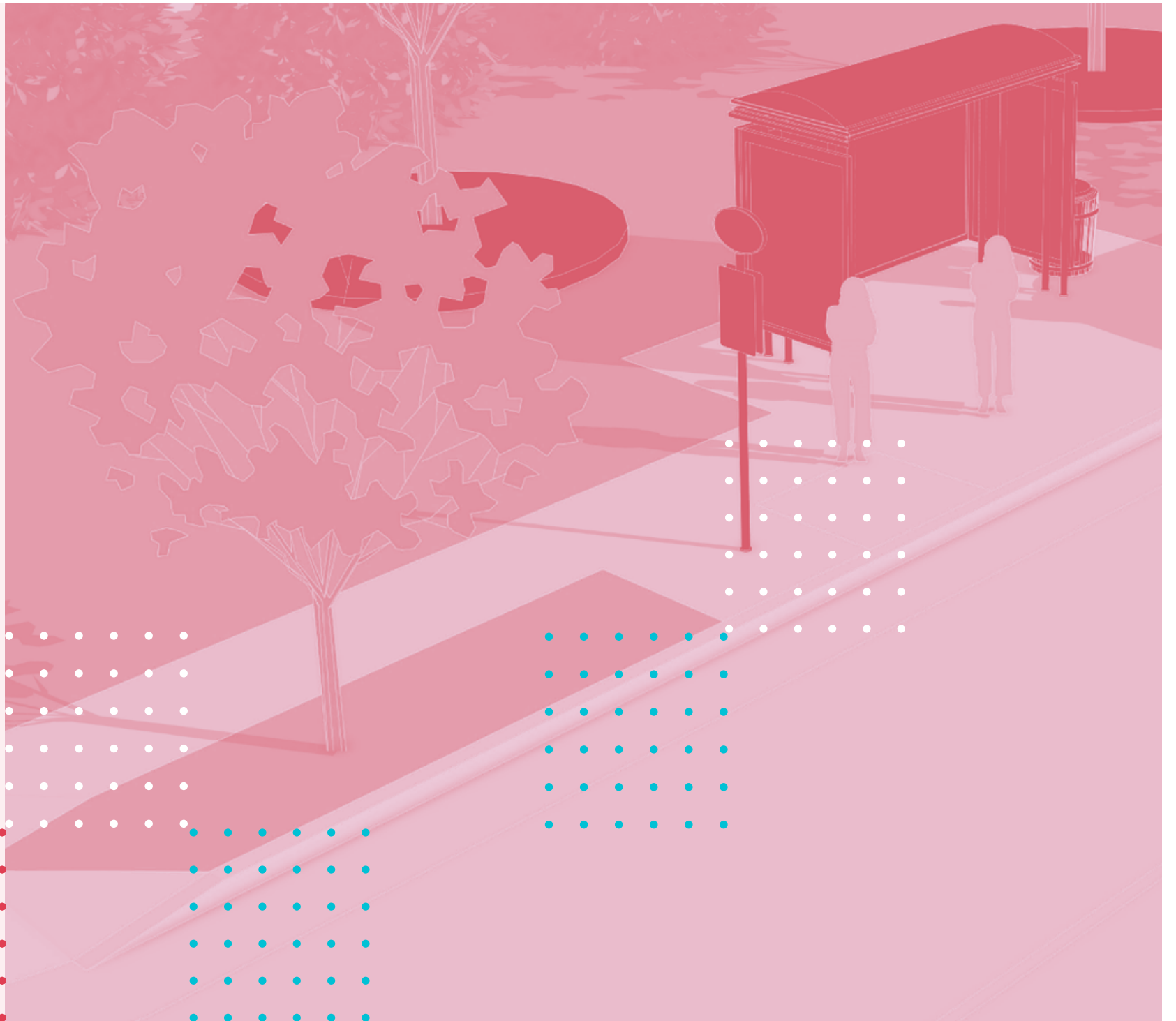

3.0 Bus Stop Design

Placement of Amenities

3.2



3.0 Bus Stop Design

3.2 Placement of Amenities

Clear Zone and Lateral Offset

Roadway safety design factors include consideration of placement of roadside objects to minimize the likelihood that a vehicle that runs off the road will crash into an object. The unobstructed area beyond the traveled way that is provided for an errant vehicle to recover is referred to as the **clear zone**.

When placing bus stop amenities such as shelters within VDOT right of way, the designer shall locate them in accordance with VDOT's clear zone and lateral offset requirements. These can be found in Appendix A2 of the VDOT *Road Design Manual*.



THE DESIGN SHALL CONSIDER THE CHARACTERISTICS OF THE ADJACENT ROADWAY, INCLUDING (BUT NOT LIMITED TO) THE FOLLOWING:

- 1 Design speed.
- 2 Traffic volumes.
- 3 Foreslopes and backslopes.
- 4 Type of surrounding development.
- 5 Treatment along the outside edge of pavement (shoulder or curb).

Edge of Travelway

Travel Lanes

Clear Zone



The AASHTO Roadside Design Guide and VDOT Road Design Manual, Appendix A2, provide guidance regarding clear zone principles.

3.0 Bus Stop Design

3.2 Placement of Amenities

Clear Zone and Lateral Offset (cont'd)

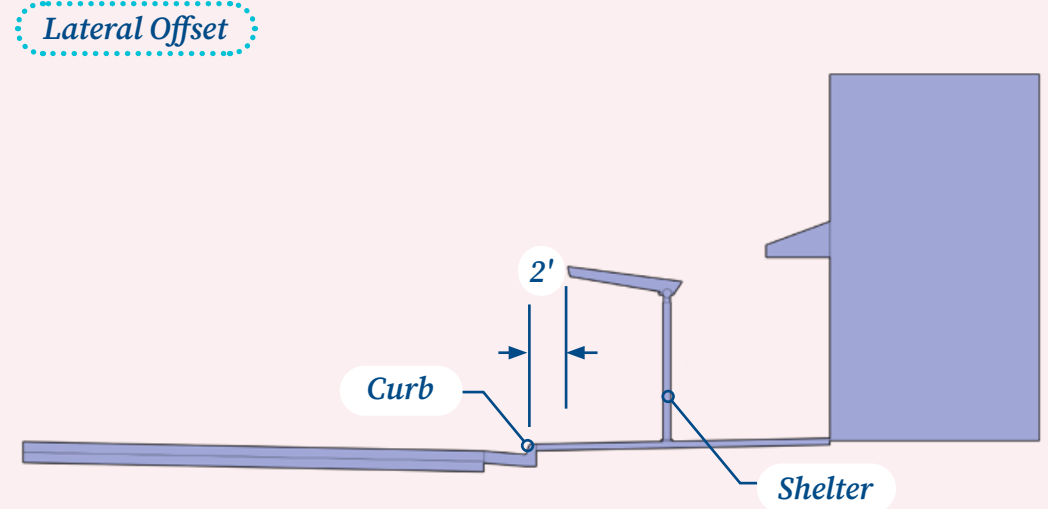

FOR BUS STOPS ON ROADWAYS WITH SHOULDERS, no non-breakaway objects will be permitted in the clear zone. Most bus shelter models are considered non-breakaway objects.



FOR BUS STOPS ON ROADWAYS WITH CURB (OR CURB AND GUTTER), non-breakaway objects such as shelters are recommended to be placed outside of the clear zone where possible. However, when curb is present, VDOT or the locality at its discretion may use lateral offset requirements to permit a non-breakaway object within the clear zone on a case-by-case basis. The preferred location to place shelters is behind the sidewalk, or as far back from the curb as practical.

To provide lateral clearance for bus mirrors when pulling up to a bus stop next to a curb, shelters shall be placed so that any part (including the canopy roof) is at least 2 feet from the face of curb.



On low-speed streets in urban areas, the locality may prefer to place shelters and bus stop amenities closer to the curb, similar to other street furniture. This placement may be justified with an engineering analysis that considers site conditions and other design constraints such as sight distance.

3.0 Bus Stop Design

3.2 Placement of Amenities

Bus Stops Adjacent to Shared-Use Paths or Bicycle Facilities

When a bus stop is located adjacent to a shared-use path, cycle track, or other off-street facility designed for use by bicyclists, there shall be a minimum 3-foot lateral offset between the edge of pavement designed for use by bicyclists and any obstruction such as shelters, benches, or signs. The preferred location to place shelters is in front of the shared-use path or other facilities for bicyclists to minimize adverse interactions between riders, and pedestrians waiting at the bus stop.

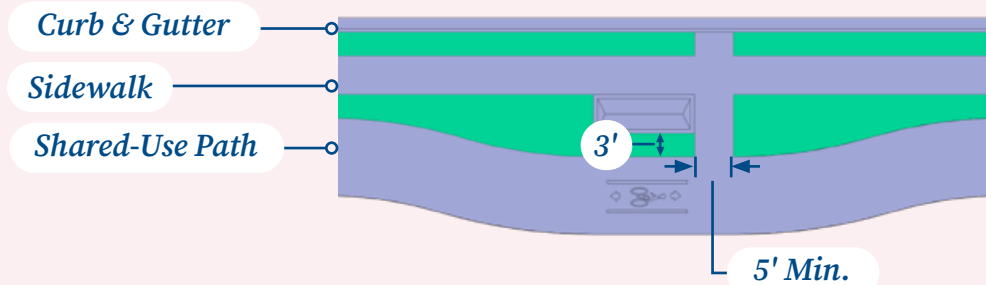

3.0 Bus Stop Design

Utilities

Utility equipment and appurtenances such as poles, pedestals, boxes, or manholes can affect the design of bus stop improvements. When scoping a bus stop improvement project, the designer should be aware of existing utilities in the vicinity of the stop to determine if there may be potential conflicts. It is recommended that the designer obtain a topographic survey with subsurface utility engineering (SUE) designation, and/or VA 811 (“Miss Utility”) designation to identify the location of underground utilities in the area.

While bus stop amenities typically do not require significant excavation, placement of bus shelters above underground utilities should be avoided when possible. If site constraints require a bus shelter to be placed above utility lines, the designer should coordinate with utility owners to determine if a conflict exists and identify mitigation strategies.

3.3



3.0 Bus Stop Design

Safety and Security

3.4



3.0 Bus Stop Design

3.4 Safety and Security

General Considerations

When designing a bus stop site, evaluate the surrounding area for feasible ways to improve safety and security for transit passengers. Principles of *Crime Prevention Through Environmental Design (CPTED)* can be useful in developing bus stop designs, especially maintenance of clear sight lines in all directions.

Crime Prevention Through Environmental Design (CPTED)

CPTED uses urban and architectural design to reduce opportunities for criminal activity. It includes maximizing visibility of spaces through lighting, landscaping, and streetscape elements.



3.0 Bus Stop Design

3.4 Safety and Security

Bus Stop Lighting

Since many passengers use transit services after dark, lighting should be provided at bus stops whenever possible. Lighting improves the passenger experience and increases comfort and safety around bus stops.



Additional information regarding lighting at bus stops can be found in Section 4.8.

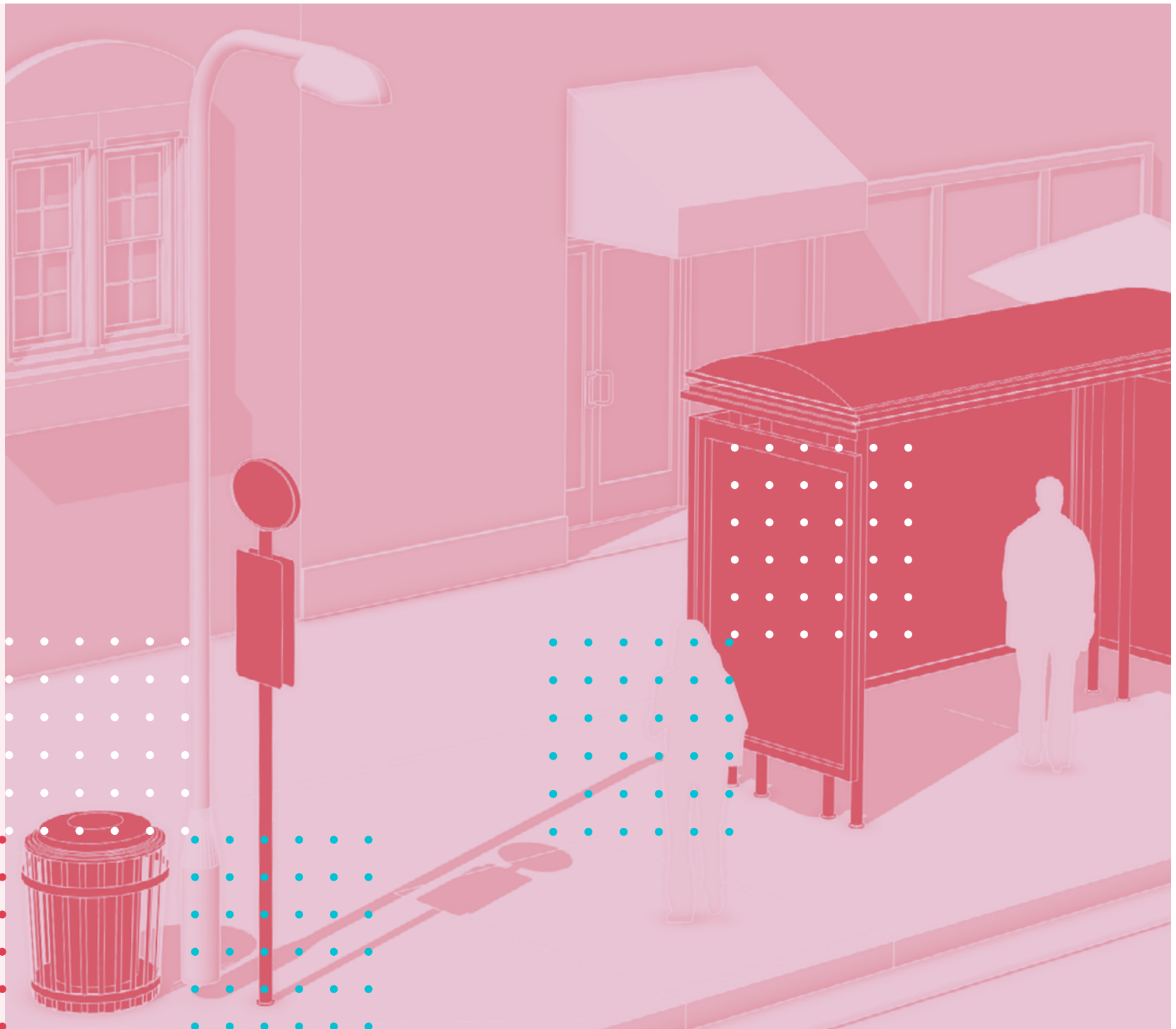

3.0 Bus Stop Design

Landscaping

Landscaping enhances the visual appeal of bus stops, and the presence of nearby trees can provide additional shaded areas.

When locating improvements to bus stops, consider potential impacts to trees and other landscaping. When possible, concrete sidewalks and foundation pads should not be located near tree roots. Bus shelters and benches should be placed so landscaping does not obstruct the ability of waiting passengers to

see approaching buses, or of bus operators to see if passengers are waiting at a stop.

Landscaping near bus stops must be maintained for passenger safety and accessibility. Required clear spaces and accessible routes cannot be obstructed by landscape elements. Prior to constructing improvements to a bus stop, the transit agency should understand who is responsible for landscape maintenance, regardless of whether the adjacent property is publicly or privately owned.

3.5



3.0 Bus Stop Design

Landscaping (cont'd)



Landscaping Adjacent to Bus Stop

Passenger Amenities

4.0

This section outlines design considerations for passenger amenities at bus stops. The transit agency serving the bus stop, in conjunction with partner localities and/or other stakeholders, will determine which amenities are to be placed at a given bus stop.

4.0 Passenger Amenities

Bus Stop Sign

Bus stop signs are a key part of a transit system's identity in the community, as they indicate to passengers, bus operators, and other roadway users where stops are located to see if passengers are waiting at a stop.

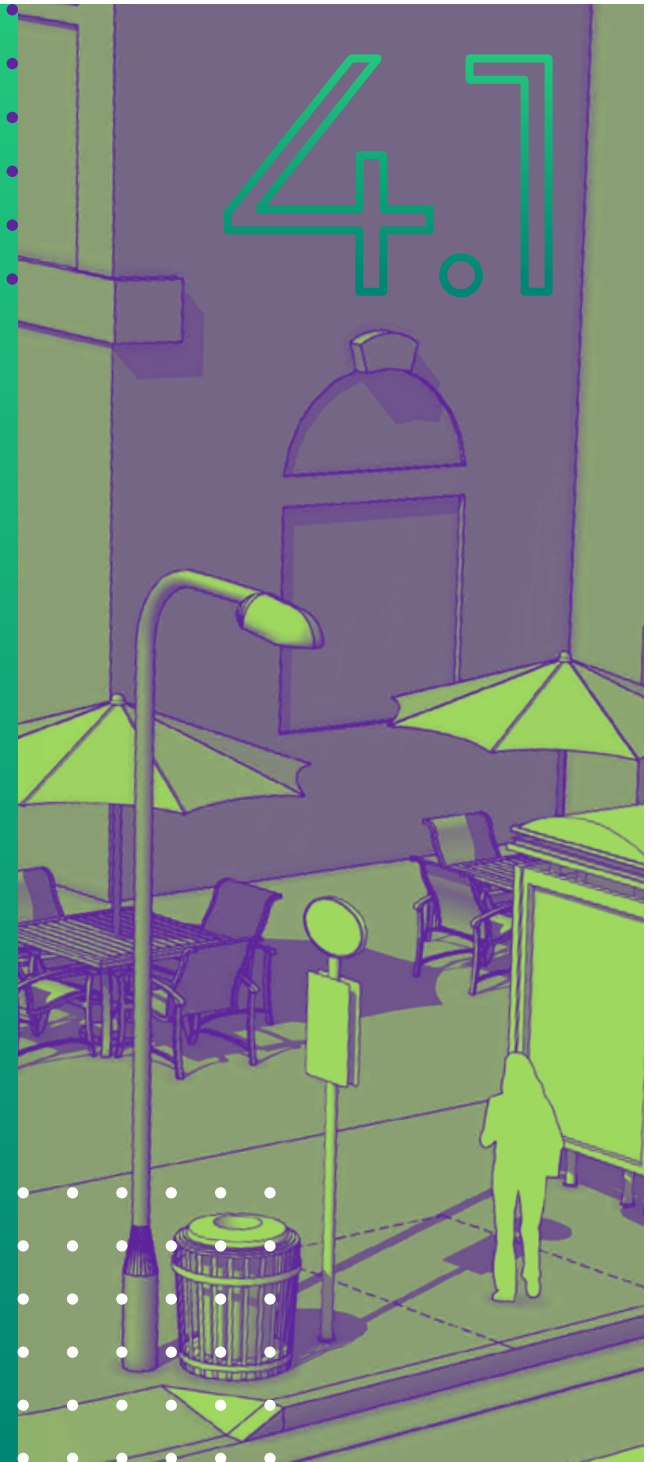

4.0 Passenger Amenities

4.1 Bus Stop Sign

Bus Stop Sign Design

Bus stop signs may vary in size, shape, and content, depending on the preferences of the transit agency. However, signage should remain consistent across all stops in a transit agency's system.

Signs must comply with applicable sections of the [Manual on Uniform Traffic Control Devices for Streets and Highways \(MUTCD\)](#) and PROWAG. Signs should use retroreflective material to enhance nighttime visibility.

Aa

TEXT CHARACTERS ON SIGNS MUST BE ACCESSIBLE IN COMPLIANCE WITH SECTION R410 OF PROWAG, WHICH INCLUDES THE FOLLOWING:

- 1 Characters shall contrast with their background.
- 2 Characters and background of signs shall have a non-glare finish.
- 3 Characters may be uppercase, lowercase, or a combination of both.
- 4 Characters shall be conventional in form.
- 5 Characters shall not be italic, oblique, script, highly decorative, or other unusual form.
- 6 Characters shall be selected from fonts where the width of the uppercase letter "O" is 55 percent minimum and 110 percent maximum of the height of the uppercase letter "I".
- 7 Characters and numbers are to be sized according to the viewing distance from which they are intended to be read (refer to PROWAG Table R410.6).
- 8 Minimum and maximum stroke thickness, character spacing, and line spacing are functions of the character height.

Manual on Uniform Traffic Control Devices for Streets and Highways (MUTCD)

The MUTCD defines the standards for signs, pavement markings, and other traffic control devices on roads and pedestrian and bicycle facilities in the United States. The MUTCD is published by the Federal Highway Administration (FHWA).



4.0 Passenger Amenities

4.1 Bus Stop Sign

Bus Stop Sign Design (cont'd)



GRTC Bus Stop Sign



OmniRide Bus Stop Sign



Loudoun County Transit Bus Stop Sign

4.0 Passenger Amenities

4.1 Bus Stop Sign

Bus Stop Sign Placement

Bus stop sign placement may vary depending on the practices of the transit agency. Signs are commonly placed at the front of the bus stop zone as a guide for the operator to stop the front of the bus so that the front door opens to the boarding and alighting area. If the sign is used as a stopping point for the front of the bus, it should be located 2 feet ahead of the designated boarding and alighting area for standard buses. This distance may vary for other types of transit vehicles.

It is preferred to mount bus stop signs on their own post and not on shared posts with other types of road signage. Sign posts shall be installed according to the requirements of the appropriate jurisdiction (VDOT or locality). Signs should be placed where they are clearly visible

to bus operators. They must not obstruct drivers' views of other roadway signs. The pole and sign shall be set with a lateral clearance of at least 2.0 feet from the face of the curb to avoid being struck by bus mirrors.

Signs shall be placed so that there is at least 6 feet, 8 inches of clearance from the bottom of the sign to the ground below. However, it is recommended to install signs with at least 7 feet to 8 feet of vertical clearance.

Bus stop signs should be set back from driveways to avoid being struck by entering or exiting vehicles.

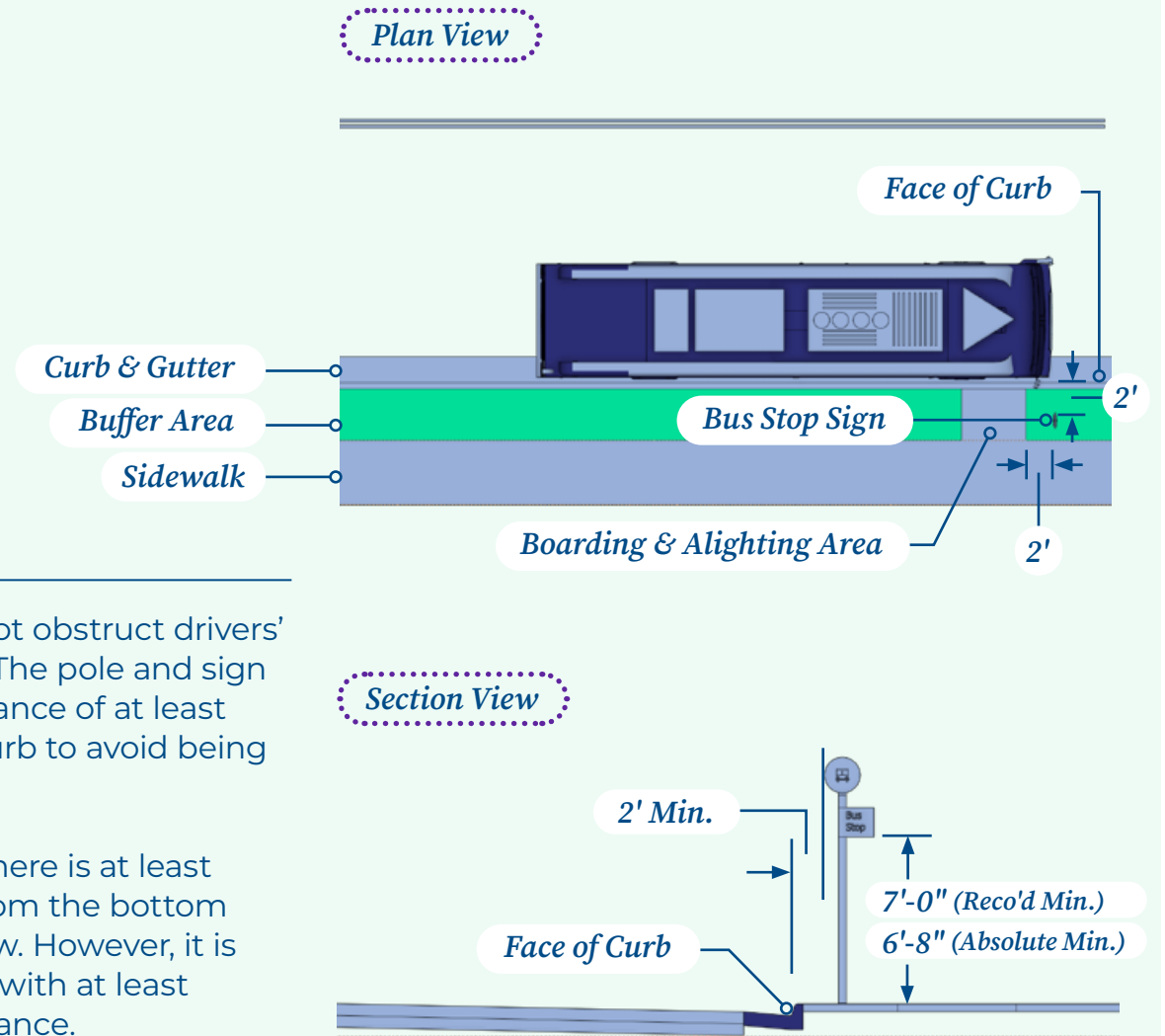

4.0 Passenger Amenities

Boarding and Alighting Area

To provide an accessible space for people using wheelchairs and other mobility devices to get on and off the bus, a boarding and alighting area is required under ADA and PROWAG. This area is sometimes also referred to as a “landing pad” or “loading pad”. If any improvements are made to a bus stop, including installation of benches or shelters, an accessible boarding and alighting area must be included if one does not currently exist.

PROWAG and many existing transit stop design references differentiate the boarding and alighting area from a “boarding platform.” The term “boarding platform” typically refers to bus stops that are elevated above the surrounding curb height to provide level or near-level boarding, including many bus rapid transit (BRT) systems and off-street transit stations. Platforms are also used to describe rail transit stops and stations of all types, including for streetcars and street-running light rail.

Different accessibility requirements apply for bus boarding platforms, including coordination of the platform floor height with the vehicle doors. The designer should consult ADA Guidelines, PROWAG, and other design references to determine the appropriate standards.

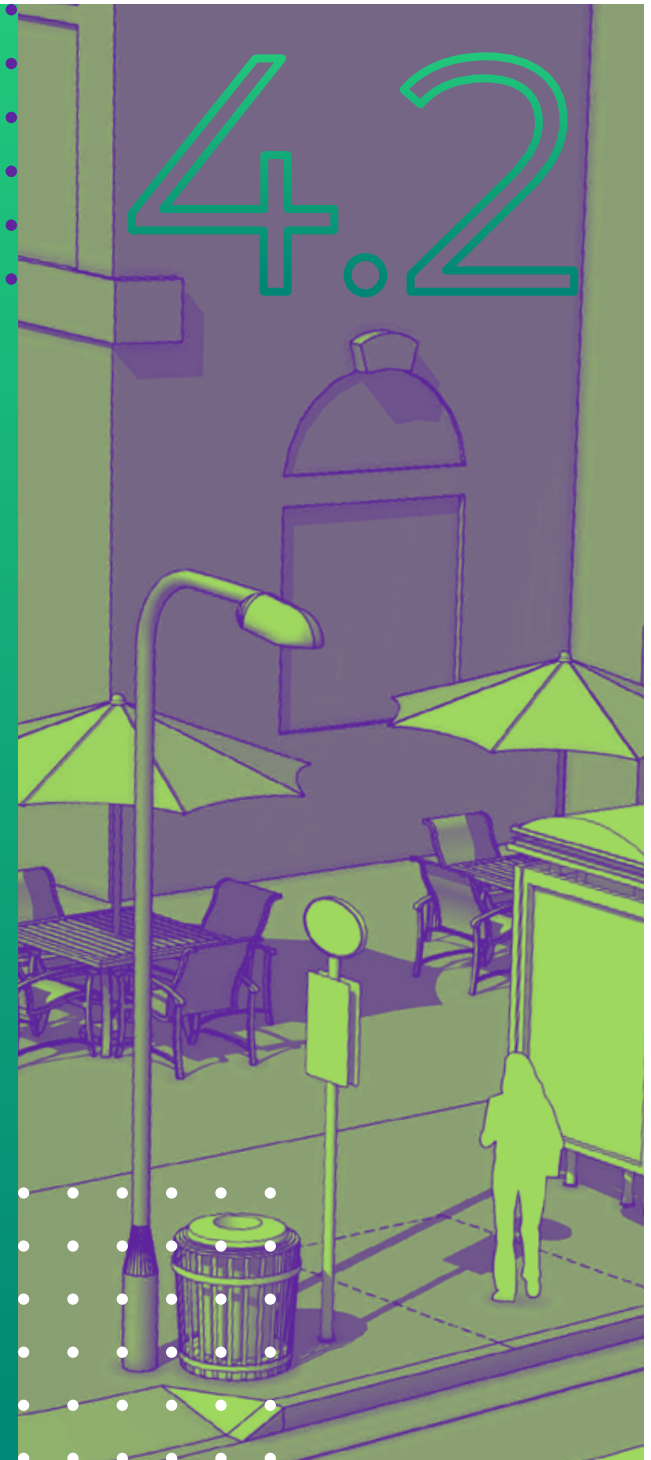

4.0 Passenger Amenities

4.2 Boarding and Alighting Area

Boarding and Alighting Area Minimum Requirements

A boarding and alighting area must be provided for any door on the bus that is accessible (i.e., the door has a ramp, lift, or other mechanism with sufficient dimensions that enables people using a wheelchair or other mobility device to get on or off the bus). Bus stop designers should confirm with the transit agency the location of accessible doors on vehicles that will be serving the bus stop. On many standard buses in use, only the front door is accessible.



THE BOARDING AND ALIGHTING AREA SHALL HAVE THE FOLLOWING CHARACTERISTICS:

- 1 Surfaces shall be stable, firm, and slip resistant.
- 2 Minimum clear length of 8 feet, measured perpendicular to the face of curb (or roadway edge of pavement, if a curb does not currently exist).
- 3 Minimum clear width of 5 feet, measured parallel to the street.
- 4 Slope parallel to the street shall be the same as the grade of the street.
- 5 Cross slope perpendicular to the street shall be 1:48 (2.1%) maximum.



Larger boarding and alighting areas of at least 7 feet or 8 feet parallel to the street are recommended to account for variability in where the door might be when a bus stops.

For bus stops in VDOT right of way, the VDOT *Road Design Manual* requires a minimum 8-foot by 25-foot concrete boarding area to accommodate both doors of a bus. Please see the next section for further information.

Listed cross slopes are maximum values. To account for reasonable construction tolerances, designed cross slopes should be 1.5% or less.

Concrete is the recommended surface material for boarding and alighting areas. Brick sidewalks, edge treatments, or other pavers may be used but are not recommended due to their tendency for differential settlement and ongoing maintenance required to keep the area within the maximum slope and level tolerances. If boarding and alighting areas are near trees or other landscaping, consider pre-construction clearing or other maintenance to prevent root intrusion and heaving that can cause the concrete to shift out of the maximum tolerances.



Boarding and alighting areas must not include poles, driveways, drainage structures, manholes, utility boxes, grass strips, or tree pits, and must not contain dirt or gravel.

4.0 Passenger Amenities

4.2 Boarding and Alighting Area

Boarding and Alighting Area Minimum Requirements (cont'd)

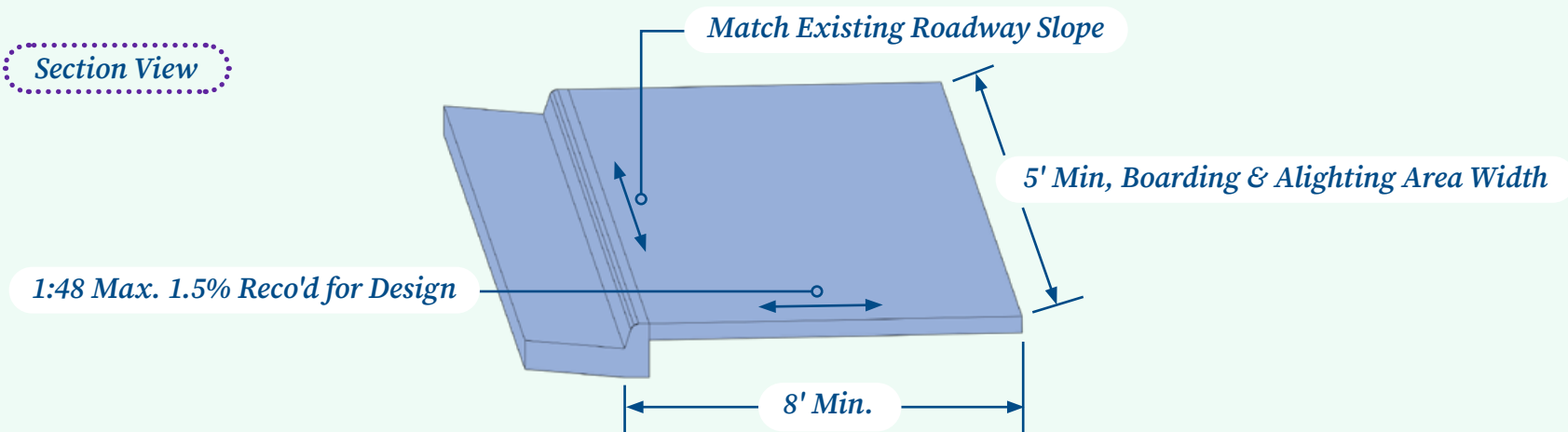
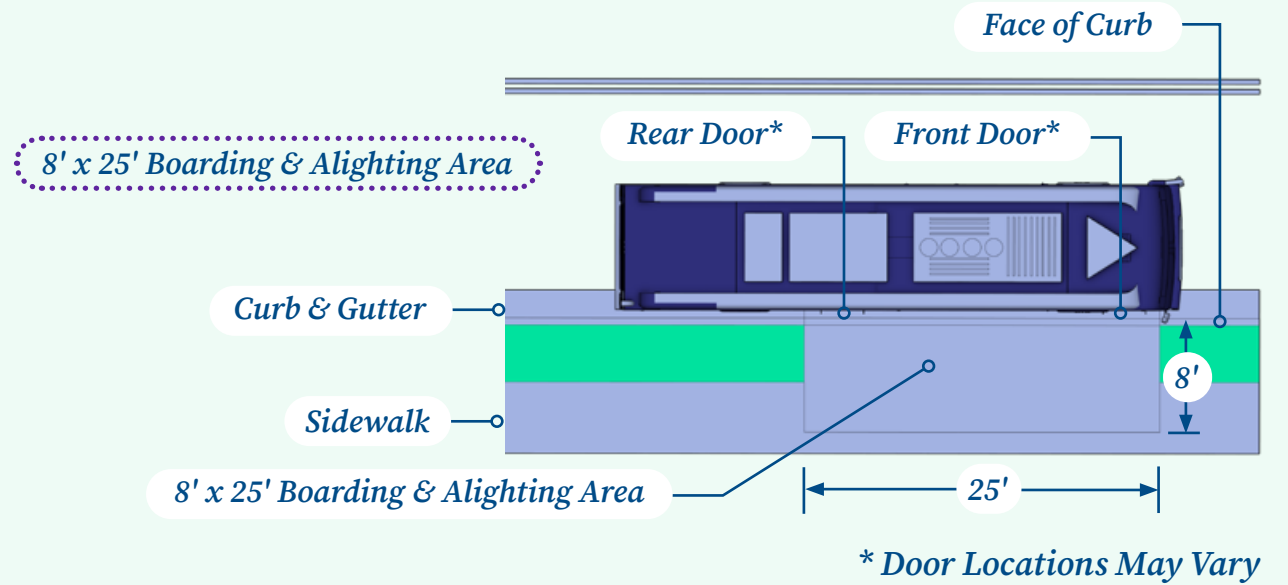
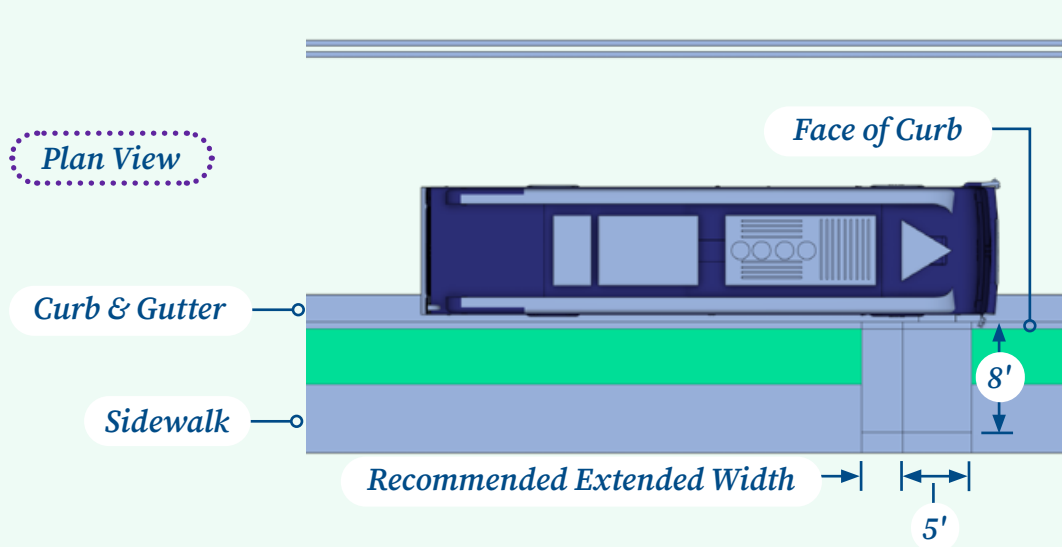

4.0 Passenger Amenities

4.2 Boarding and Alighting Area

Other Alighting Areas

In many buses, the rear exit door is not part of an accessible route and does not require a full-size boarding and alighting area. However, if buses serving the stop have multiple doors, the bus stop should also include a clear, stable, non-slip surface for alighting from rear doors.

The easiest way to implement this is to extend the boarding and alighting area to provide a large continuous clear area along the curb that can accommodate both the front and rear door. For this type of design, an 8-foot by 25-foot area is often adequate, but the designer should confirm dimensions with the transit agency using the bus stop.

A rear door alighting area can also be constructed separate from the front door boarding and alighting area. This design may be required to accommodate landscaping, signs, or other elements near the bus stop. The location and size of the separate rear door alighting area should be designed based on vehicle dimensions of the buses serving the stop. An approximate design standard is to provide a minimum 6-foot-wide space at the rear door location when the bus is stopped at the front boarding and alighting area, but it should be sized to accommodate all vehicles that serve the stop.

Separate Rear Door Alighting Area

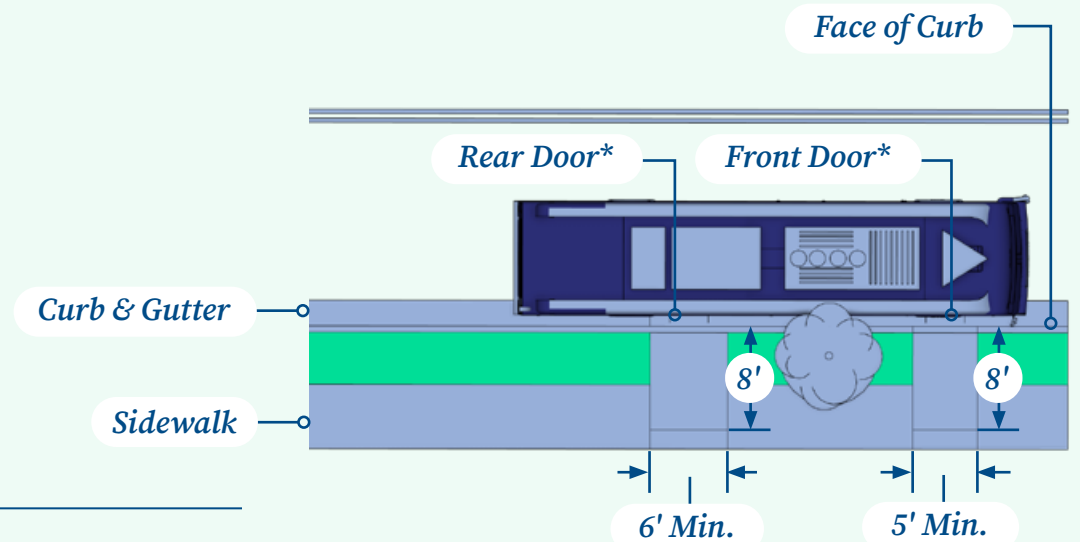

* Door Locations May Vary

4.0 Passenger Amenities

Accessible Pedestrian Routes

PROWAG and ADA Guidelines require that the boarding and alighting area be connected to shelters, benches, information signs, and other bus stop amenities via accessible pedestrian routes.

Pedestrian facilities placed in VDOT right of way must comply with VDOT policy for pedestrian access routes, which can be found in Appendix A(1) of the Road Design Manual.



ACCESSIBLE PEDESTRIAN ROUTES HAVE THE FOLLOWING CHARACTERISTICS:

- 1 Stable, firm, and slip-resistant surface.
- 2 Absolute minimum width of 4 feet, preferred minimum width of 5 feet. In areas of 4-foot sidewalks, 5-foot by 5-foot passing zones must be provided every 200 feet.
- 3 Maximum longitudinal grade 5.0%. However, if the grade of the adjacent existing street is greater than 5.0%, the longitudinal grade of the pedestrian route shall not be greater than the grade of the existing street.
- 4 Maximum cross slope 1:48 (2.1%).

Designed cross slopes should be 1.5% or less to account for reasonable construction tolerances. For additional detail, the designer should refer to PROWAG for guidance.

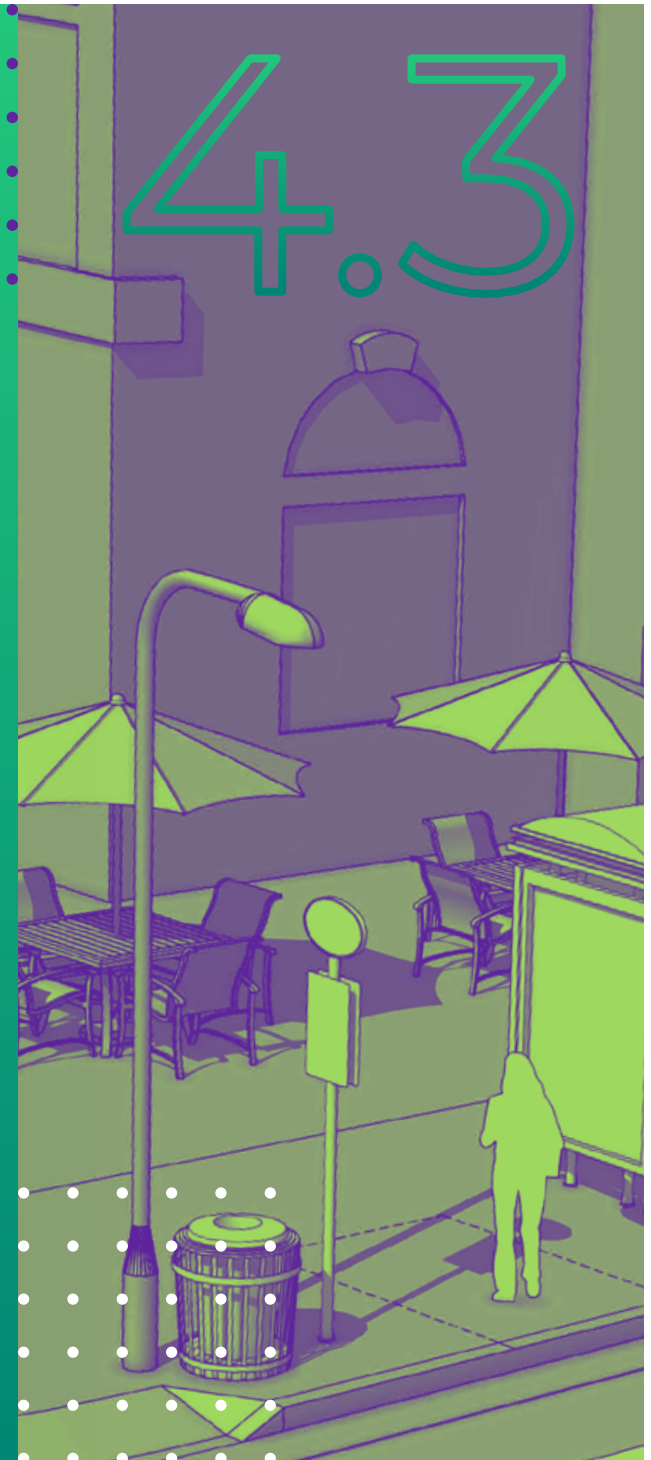

4.0 Passenger Amenities

Shelters

Bus shelters protect passengers from the sun and inclement weather and provide seating while they wait.



TRANSIT AGENCIES SHOULD CONSIDER THE FOLLOWING FACTORS WHEN DECIDING WHETHER TO INSTALL A SHELTER AT A PARTICULAR LOCATION:

- 1 Number of daily boardings.
- 2 Available space to install amenities:
 - Is there sufficient right of way, or can an easement (or other access agreement) be obtained to install the shelter and connecting paths?
 - Are there any utility conflicts?
- 3 Accessible connections to the surrounding area.
- 4 Site-specific climate conditions:
 - Is the stop exposed to the sun, or located in a particularly windy area?
- 5 Frequency of service:
 - If service is less frequent, passengers are more likely to be waiting at the bus stop for longer periods of time.
- 6 Distribution of amenities across the agency's service area.

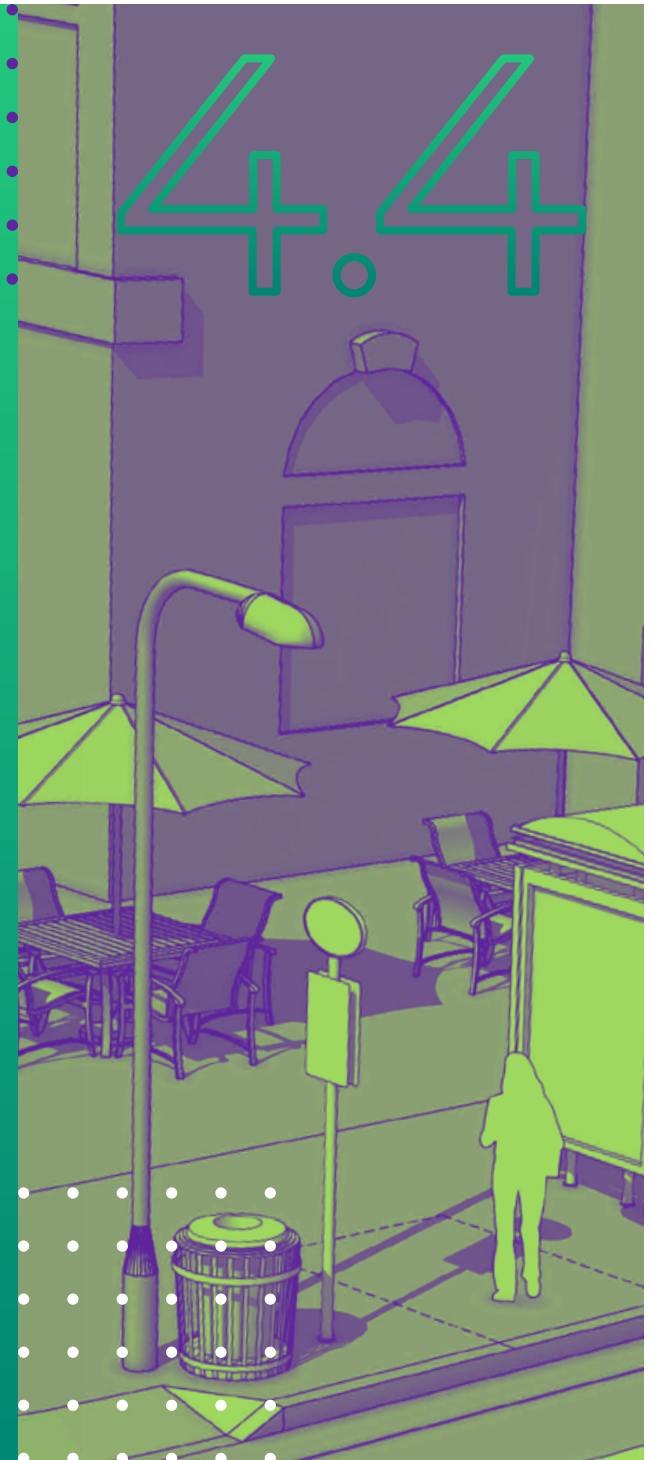

4.0 Passenger Amenities

4.4 Shelters

Shelter Design

The shelter's architectural style is determined by the transit agency and may be developed in conjunction with stakeholders such as partner localities or adjacent property owners. A variety of prefabricated shelter designs are available from multiple manufacturers. Shelters can also be custom designed for specific applications if warranted. Agencies should use consistent shelter styles systemwide to simplify maintenance and create a recognizable brand.

Multiple shelter configurations are available and can be selected based on the needs of a particular site. The transit agency, designer, and stakeholders will need to select the number of walls, size of walls, and roof style to be used for the shelter. Walls on each side provide

greater protection from the elements, but site constraints might dictate the need to install a shelter with a smaller footprint. Shelters with shorter walls or even a full cantilever design provide shade but less protection from wind, rain, or snow.



Shelter windows may incorporate panels for passenger information, maps, or advertising (note that advertisements are not permitted on shelters located in state rights of way).

If seating is provided under the shelter roof, ADA and PROWAG require an accessible clear space to be provided within the shelter. This space shall be 30 inches by 48 inches and located next to the bench.

Shelters are typically installed on a reinforced concrete foundation pad, which is different from standard 4-inch-thick concrete sidewalk. The design of the concrete foundation is to be completed under the supervision of a professional engineer licensed in Virginia, with the engineer's seal and signature. This is often arranged through the shelter manufacturer. The bus stop site designer must be aware of the shelter pad size requirements and lateral placement of the shelter on the pad in order to confirm that minimum clear widths for pedestrian accessibility are provided.

4.0 Passenger Amenities

4.4 Shelters

Shelter Design (cont'd)



Bus Shelter



Bus Shelter



Bus Shelter

4.0 Passenger Amenities

Bench Design

The placement of benches located outside of shelters should be determined by the transit agency in coordination with local governments and other stakeholders. There are many different options for bench styles, including lengths, materials, backrests, armrests, and center seat bars.

Benches should be made from materials that do not retain heat in summer, become excessively cold in winter, or collect water. Benches should be designed to be resistant to vandalism. Benches should be anchored on a concrete pad to

prevent unauthorized movement, while still allowing for relocation if needed. Benches should be at least 20 inches wide, with the seat 17 to 19 inches above the ground (refer to *ADA Accessibility Standards*, Section 903). If a full-size bench cannot be installed at a bus stop due to space constraints, seating with a smaller footprint such as pole-mounted seating may be a viable alternative.



PROWAG does not specify minimum bench seat lengths. ADA Accessibility Standards Section 903 states that for built-in benches, the minimum seat length is 42 inches, while the seat depth shall be between 20 and 24 inches.

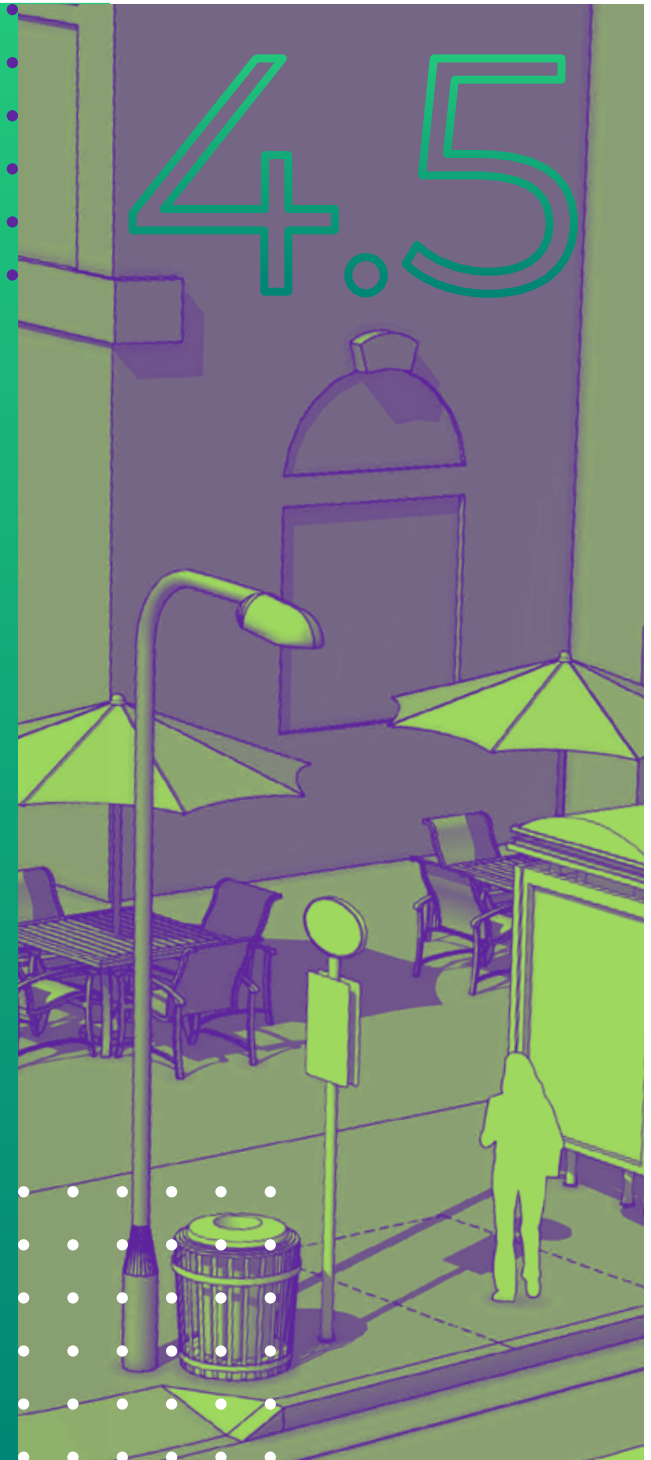

4.0 Passenger Amenities

Bench Design (cont'd)

Benches shall be located outside of accessible pedestrian routes. An 18-inch area in front of the bench shall be provided for knee and foot clearance. This space should not interfere with the accessible pedestrian route. A 30-inch by 48-inch clear space shall be provided adjacent to the bench for people using wheelchairs. The bench, knee and foot clearance, and adjacent clear space shall be connected to the boarding and alighting area and other amenities at the bus stop with accessible pedestrian routes.



Bench at Bus Stop



Bench at Bus Stop

4.0 Passenger Amenities

Trash Receptacles

Trash and/or recycling receptacles are recommended at bus stops to maintain cleanliness. They are especially recommended for high-volume locations.

The style of trash and/or recycling receptacles is to be determined by the transit agency, local jurisdiction, and/or other stakeholders. Receptacles located at bus stops should be made of materials resistant to weather and vandalism. They should be secured to prevent unauthorized movement.

If provided, receptacles must be placed adjacent to, but outside of, accessible pedestrian routes and the boarding and alighting area.

When placing a receptacle at a bus stop, there must also be a plan for regular trash collection so that overflowing waste does not create problems in the surrounding area.

Trash receptacles should not be mounted on sign poles within the roadway clear zone. Alternative placement options may include anchoring to the ground or attaching to bus shelters.

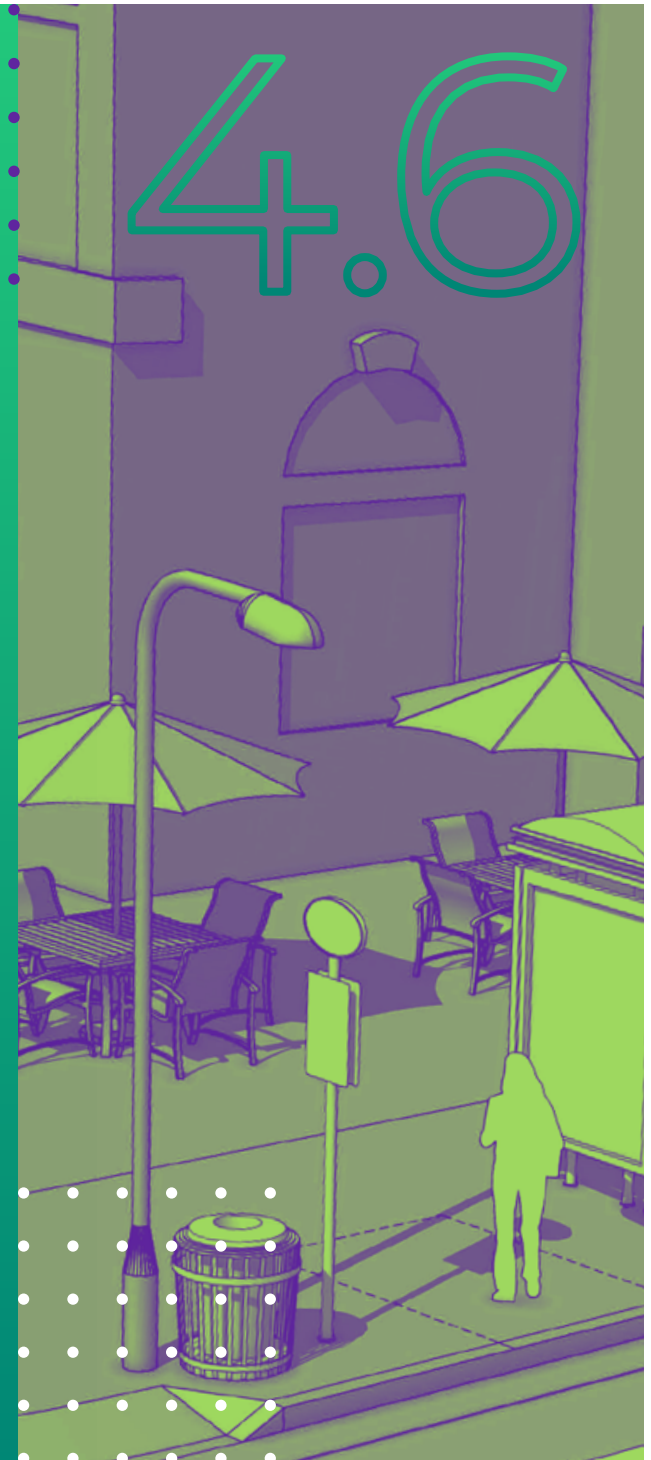

4.0 Passenger Amenities

Trash Receptacles (cont'd)



Ground-Mounted Trash Can at Bus Stop



Shelter-Mounted Trash Cans

4.0 Passenger Amenities

Bicycle Parking

When bicycle parking is provided at a transit stop, the designer should consider circulation patterns from the boarding and alighting area to bicycle storage areas and bike routes.

If bike racks or other storage is provided, they shall be placed so that parked bicycles do not obstruct accessible routes. For bus stops in areas where bikeshare or scooter services operate, consider designating a separate area outside accessible pedestrian routes for storage.

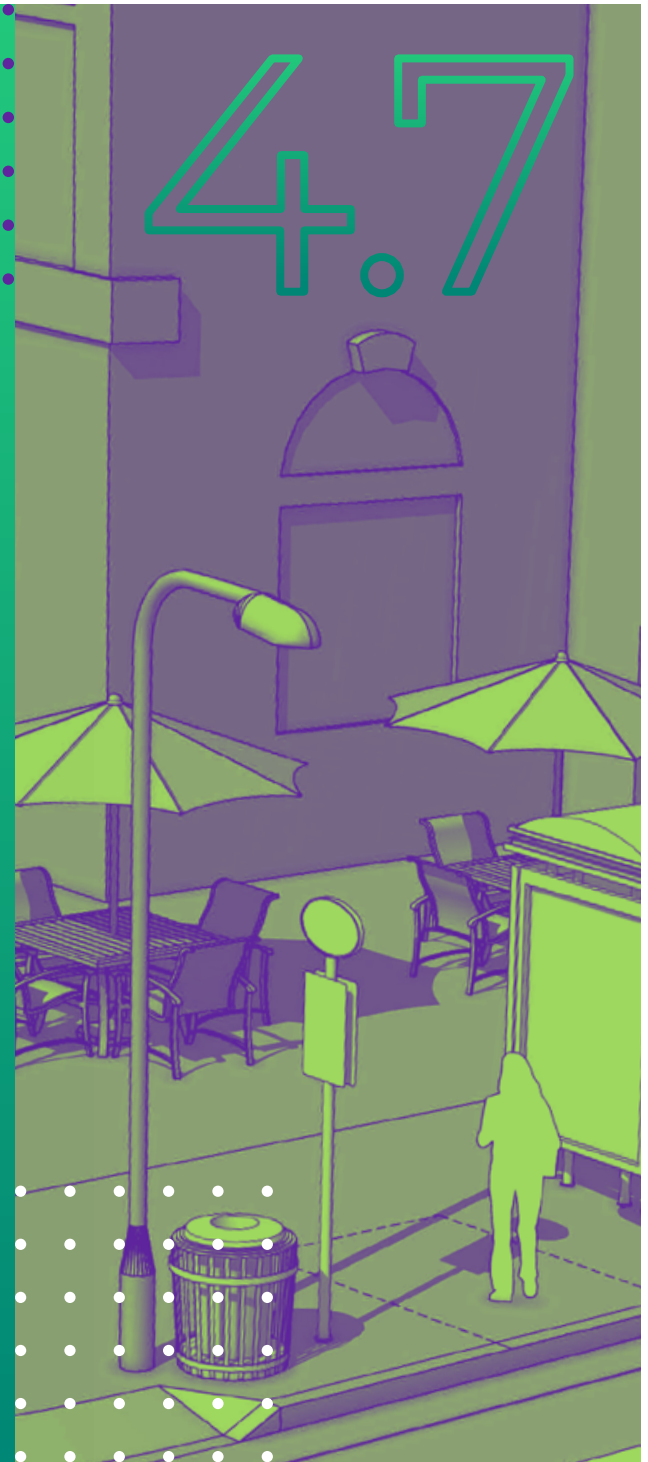

4.0 Passenger Amenities

Bicycle Parking (cont'd)

*Bike Locker**Series of Bike Lockers**Bike Racks in a Parking Garage*

4.0 Passenger Amenities

Lighting

Transit agencies are typically not responsible for installation of lighting at bus stops and nearby sidewalks along public streets. If additional permanent lighting is desired at a specific bus stop, the transit agency should coordinate with the entity responsible for providing street lighting (often the local government or VDOT).

Pedestrian-scale lighting with lamps 25 feet high or less are preferred at bus stops. Cobra-style light fixtures tend to be less effective for illuminating sidewalks and bus stops, but bus stops can be placed strategically near the light sources if necessary.

To supplement lighting at a bus stop, most shelter manufacturers provide solar-powered lighting kits that can be mounted to the shelter structure. Transit agencies might also consider pole-mounted solar lights.

When lighting is added to a site to support bus stop improvements, the total illumination should be between 2 and 5 foot-candles. Shelter lighting should be designed to the lower end of this range to avoid creating a spotlight effect that makes it difficult to see waiting passengers.

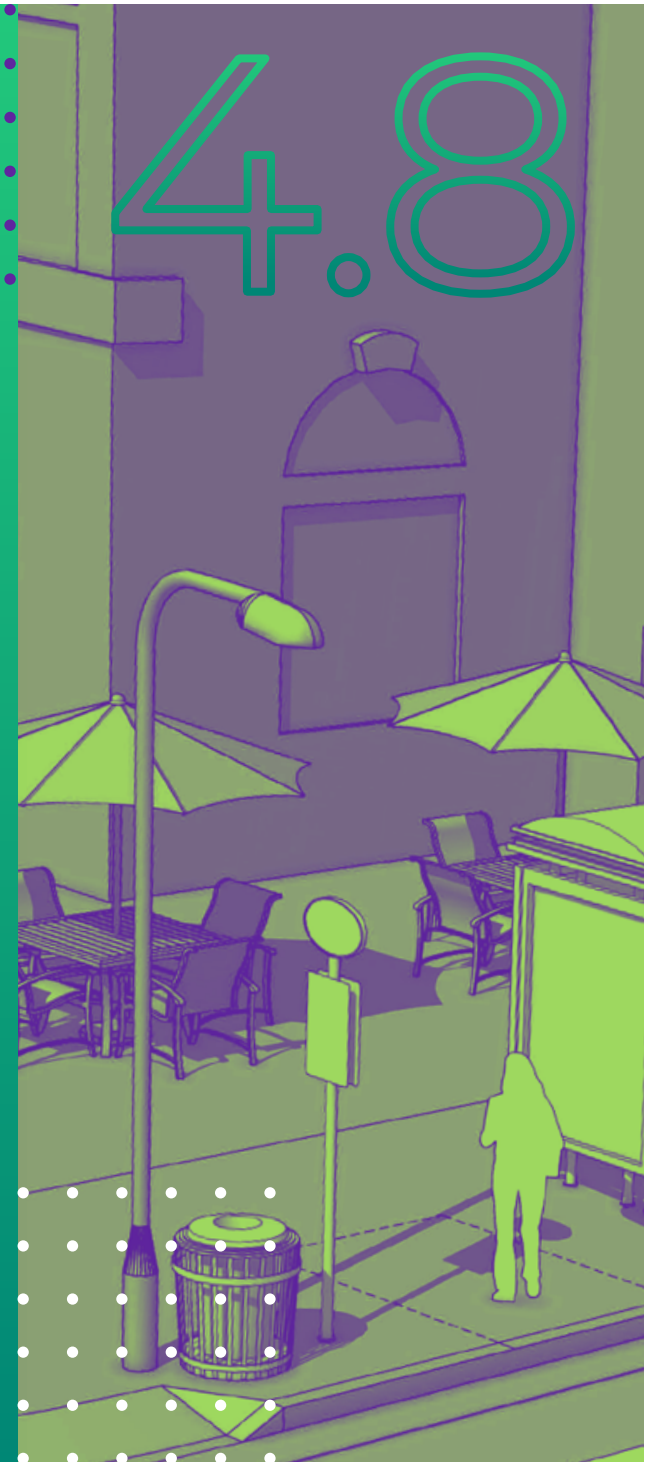

4.0 Passenger Amenities

Lighting (cont'd)



Bus Shelter with Solar-Powered Lighting



Bus Shelter with Solar-Powered Lighting

4.0 Passenger Amenities

Passenger Information

Transit agencies should consider providing information about bus schedules and other transit services at bus stops. This information can be displayed in various formats, such as panels located next to bus stop signs, inside shelters, or dedicated display boards.

Real-time information that tells passengers when the next bus is expected to arrive may be provided through digital information display screens located at the bus stop, or through smartphone apps or a transit agency's website.

All signs placed at the bus stop must comply with PROWAG and/or ADA requirements regarding mounting height, text size, color contrasts, and other sign design elements. Signs intended for use by people reading up close must be located on an accessible pedestrian route.

If information is available via smartphone apps or websites, the transit agency should present that information in a clear manner.

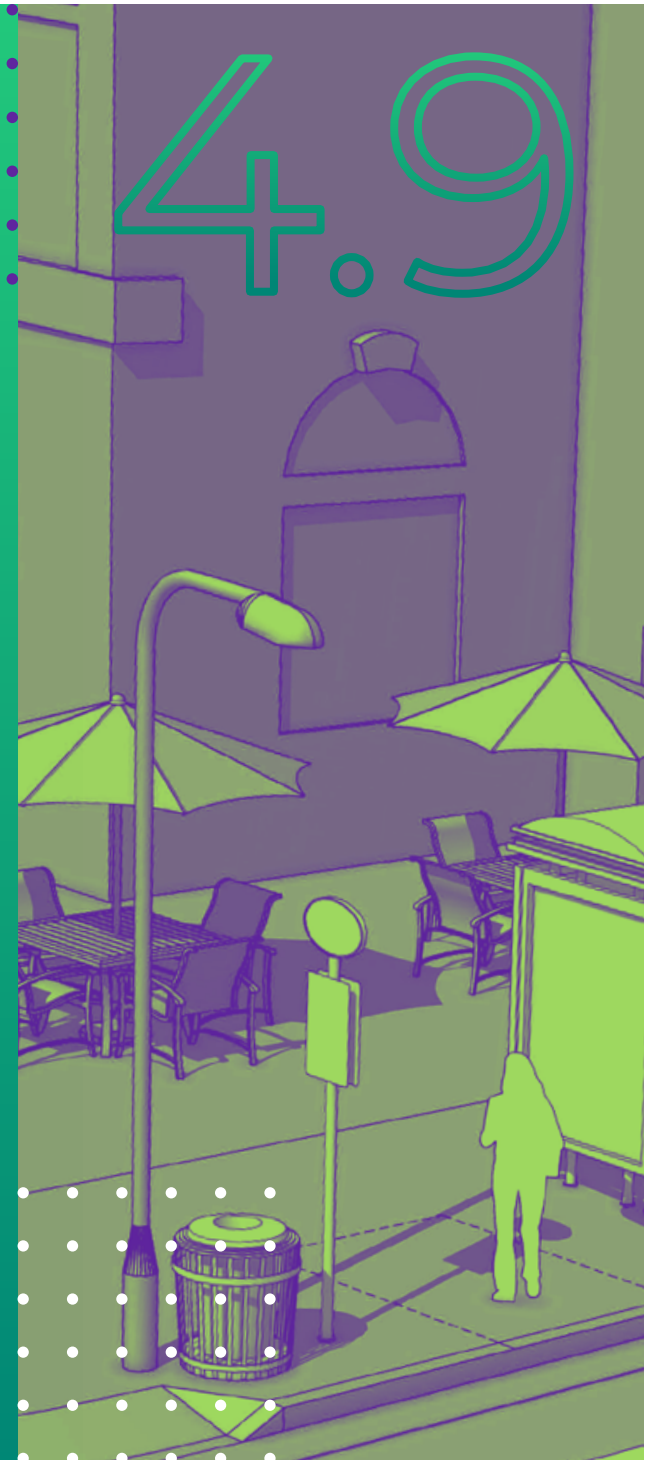

4.0 Passenger Amenities

Passenger Information (cont'd)



Pole-Mounted Display



Information Display



QR Code on Bus Stop Sign



Overhead Information Sign

4.0 Passenger Amenities

Pavement Adjacent to Bus Stops

When bus stops are served at a high frequency (more than 4 buses per hour), or where buses will be stopped for layovers, the use of concrete pavement is recommended to avoid asphalt pavement deformation and premature failures that may occur due to frequent loading, acceleration, and deceleration of heavy vehicles.



FOR BUS STOPS ALONG A VDOT-OWNED OR MAINTAINED ROAD:

Concrete pavement should be designed in accordance with VDOT's *Materials Division Manual of Instructions* [↗](#). The proposed pavement design must be included in the site plan and will be reviewed by the appropriate VDOT District Materials Division. VDOT must approve the pavement design prior to issuing the land use permit.

VDOT's Materials Division Manual of Instructions

The Manual of Instructions for the Materials Division outlines VDOT's practices for design, inspection, testing, and control of the materials used in the construction and maintenance of highways, structures, bridges, and other roadway design elements in Virginia.

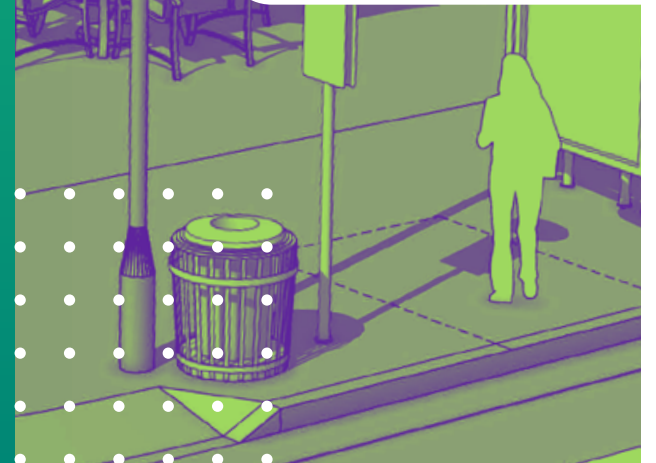

4.0 Passenger Amenities

Pavement Adjacent to Bus Stops (cont'd)

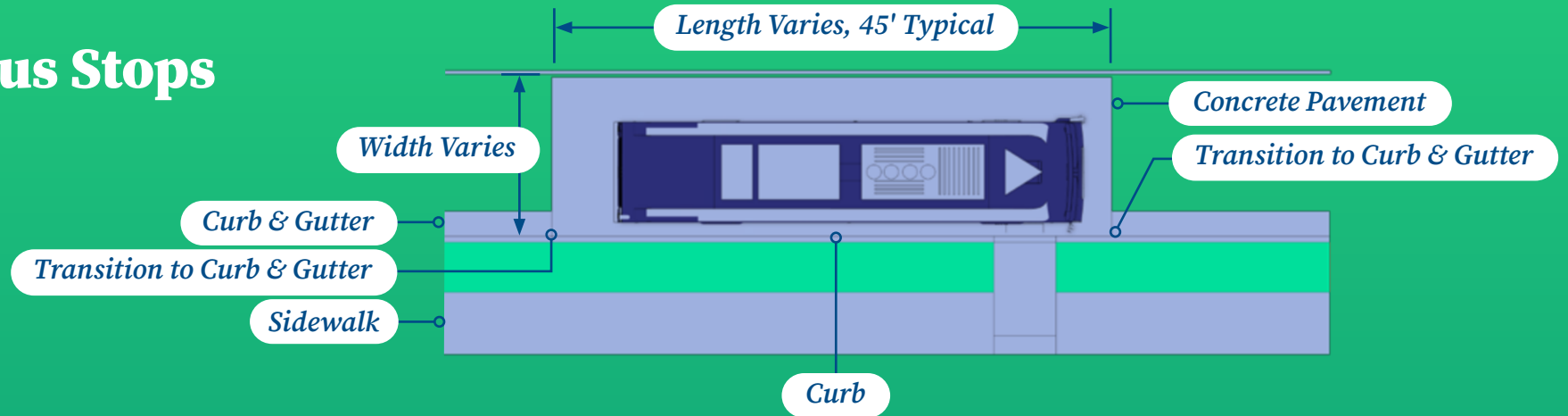

FOR BUS STOPS IN NON-VDOT LOCATIONS:

The concrete pavement design should be designed to the standards of the jurisdiction maintaining the road. The pavement design should be included in the site plan for review by the locality.

The minimum size of the concrete pavement pad should be 10 feet in width and the length of the typical bus expected to serve the stop. The concrete pavement may be larger to suit the preferences of the jurisdiction responsible for maintenance.

If the existing roadway uses a curb and gutter section, buses stopping close to the curb will pull onto the gutter pan, which is typically not reinforced. To avoid differential settlement and development of open joints between the gutter and the concrete slab that can lead to premature pavement failure, the designer should consider replacing the curb and gutter with a curb-only section (VDOT Standard CG-2 or similar) adjacent to the concrete slab.

Concrete pavement pads should not be located within crosswalks, to avoid joints or seams that might affect mobility across the crosswalk. If a concrete pad is located near an on-street bike lane, it should be located so that there are no longitudinal joints or seams within the bike lane.

4.0 Passenger Amenities

Pavement Adjacent to Bus Stops (cont'd)



Concrete Turnout at Bus Stop



Concrete Pavement at Bus Stop

Typical Design Strategies

5.0

This section includes figures depicting common bus stop improvement scenarios that may be encountered.

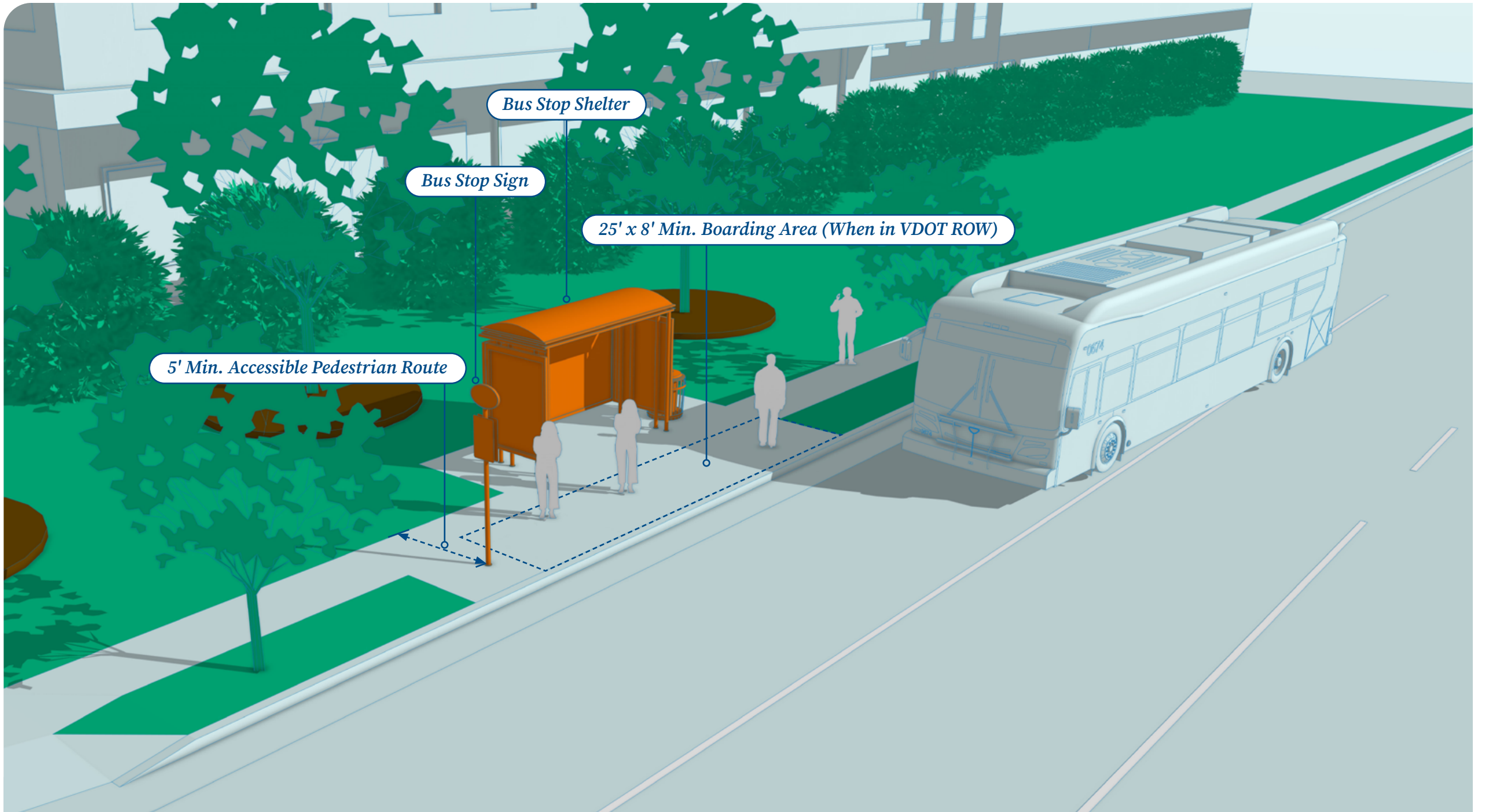

Typical Bus Stop with Existing Sidewalk and Verge

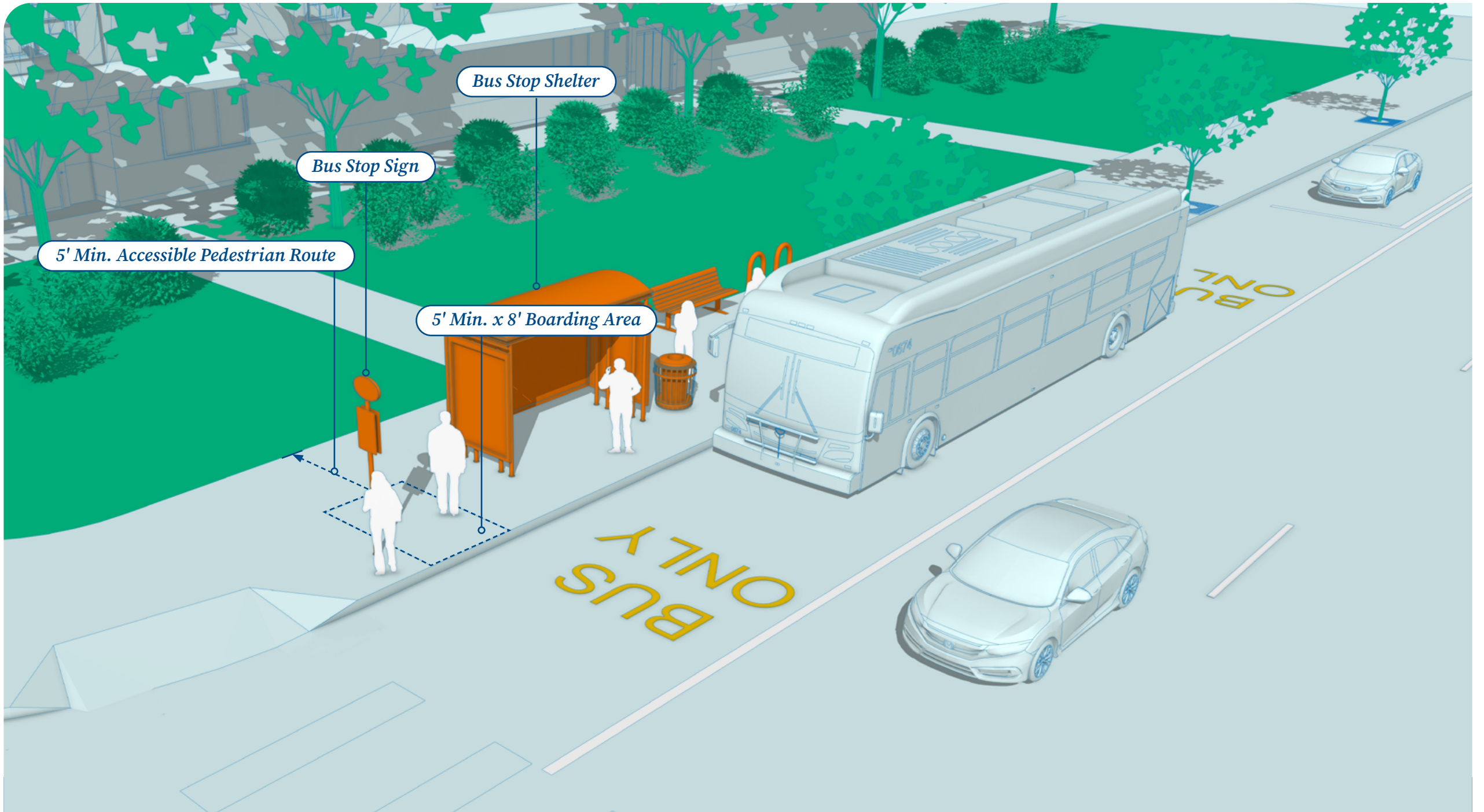

Bus Stop with Pedestrian Walkway Behind Shelter

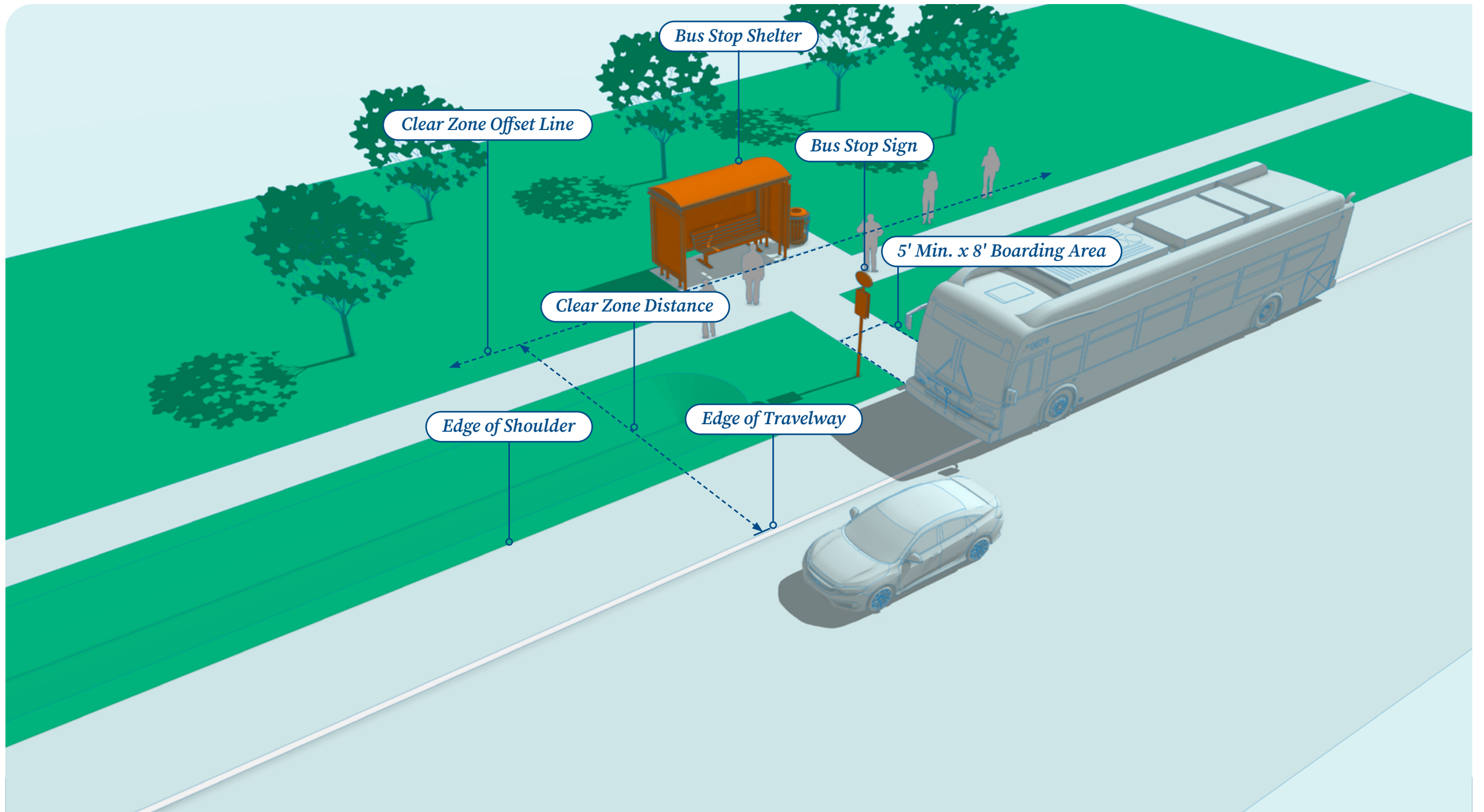

Bus Stop with Shoulder

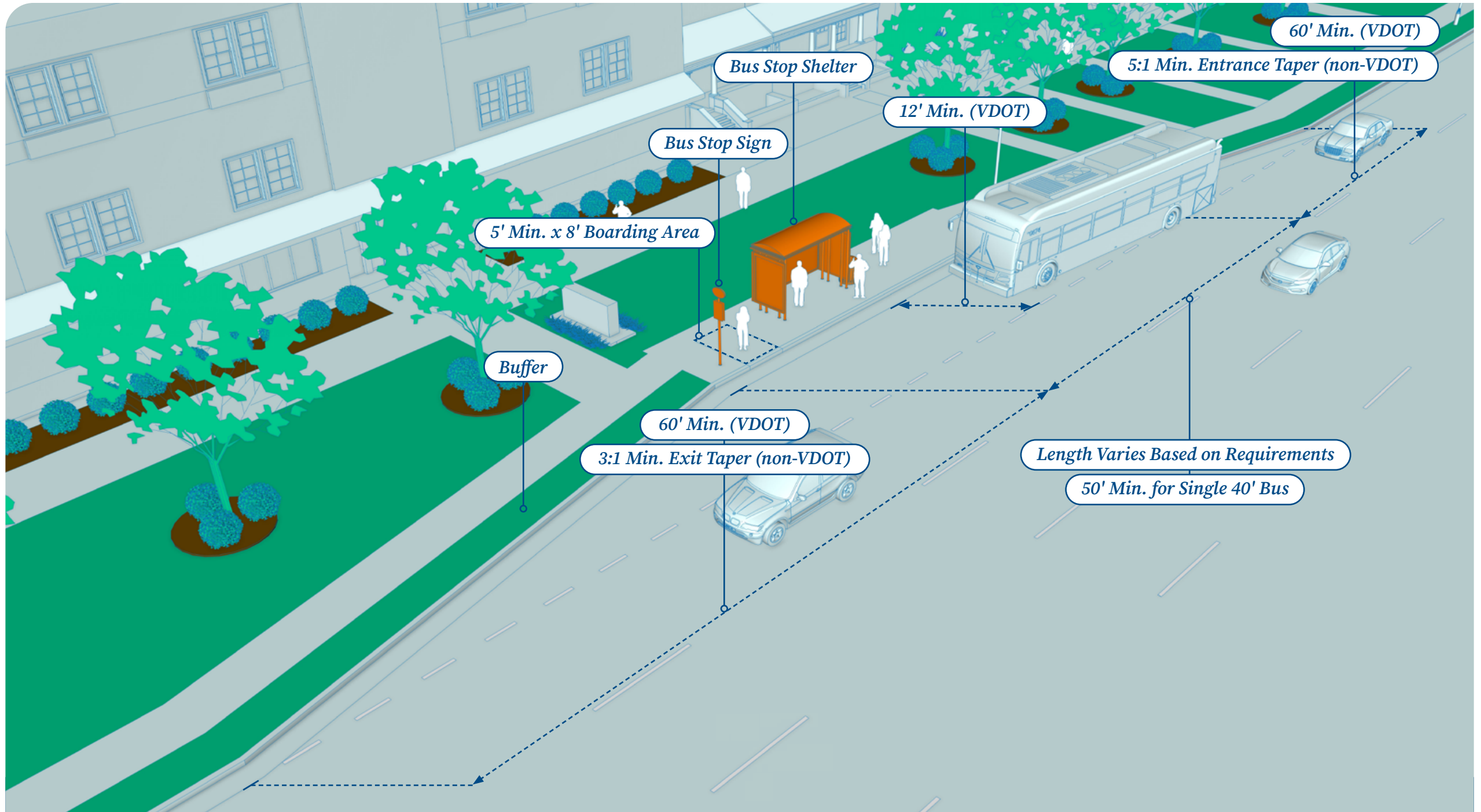

Bus Stop with Pull-Out Lane

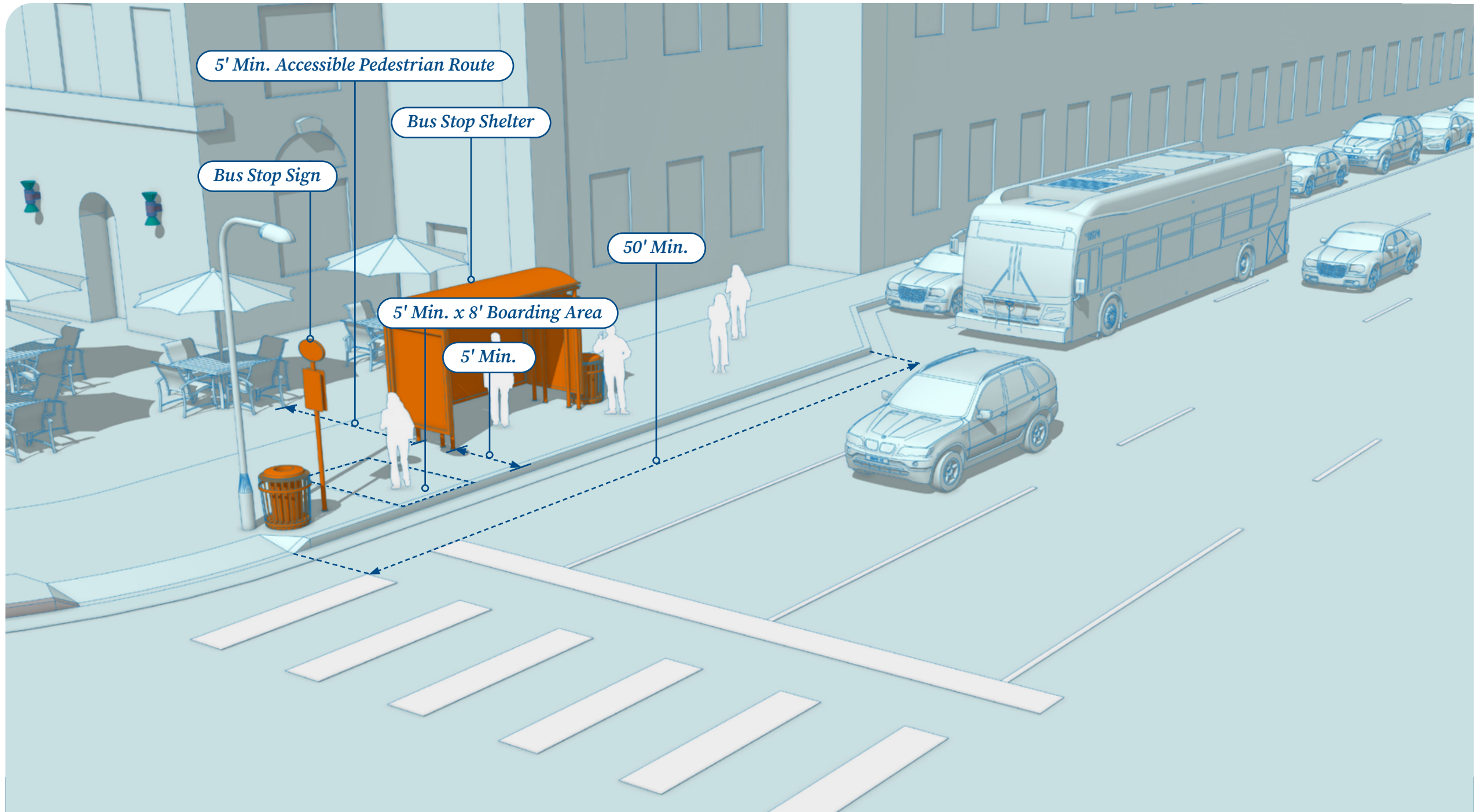

Near Side Bus Stop with Bulb-Out Sidewalk

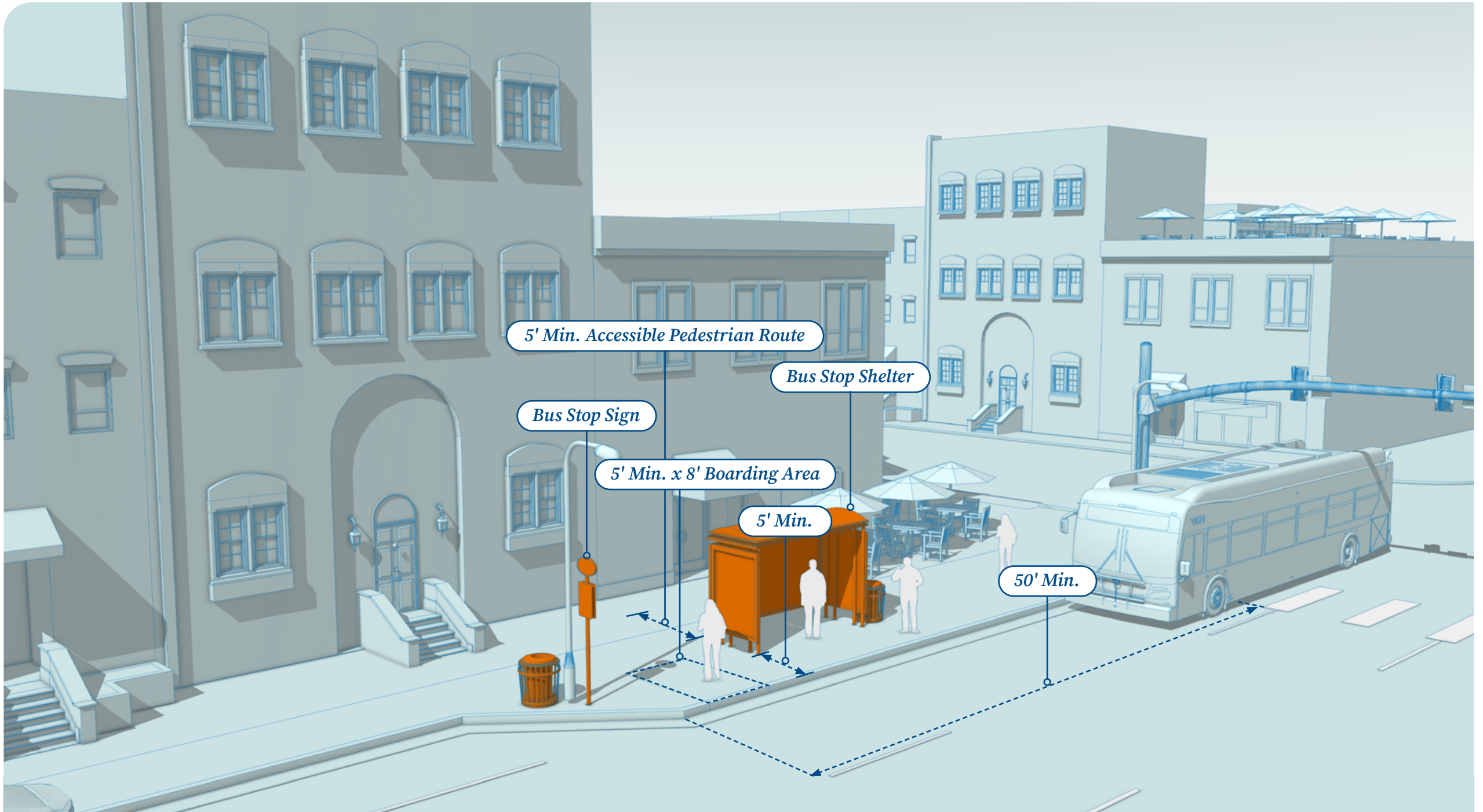

Far Side Bus Stop with Bulb-Out Sidewalk

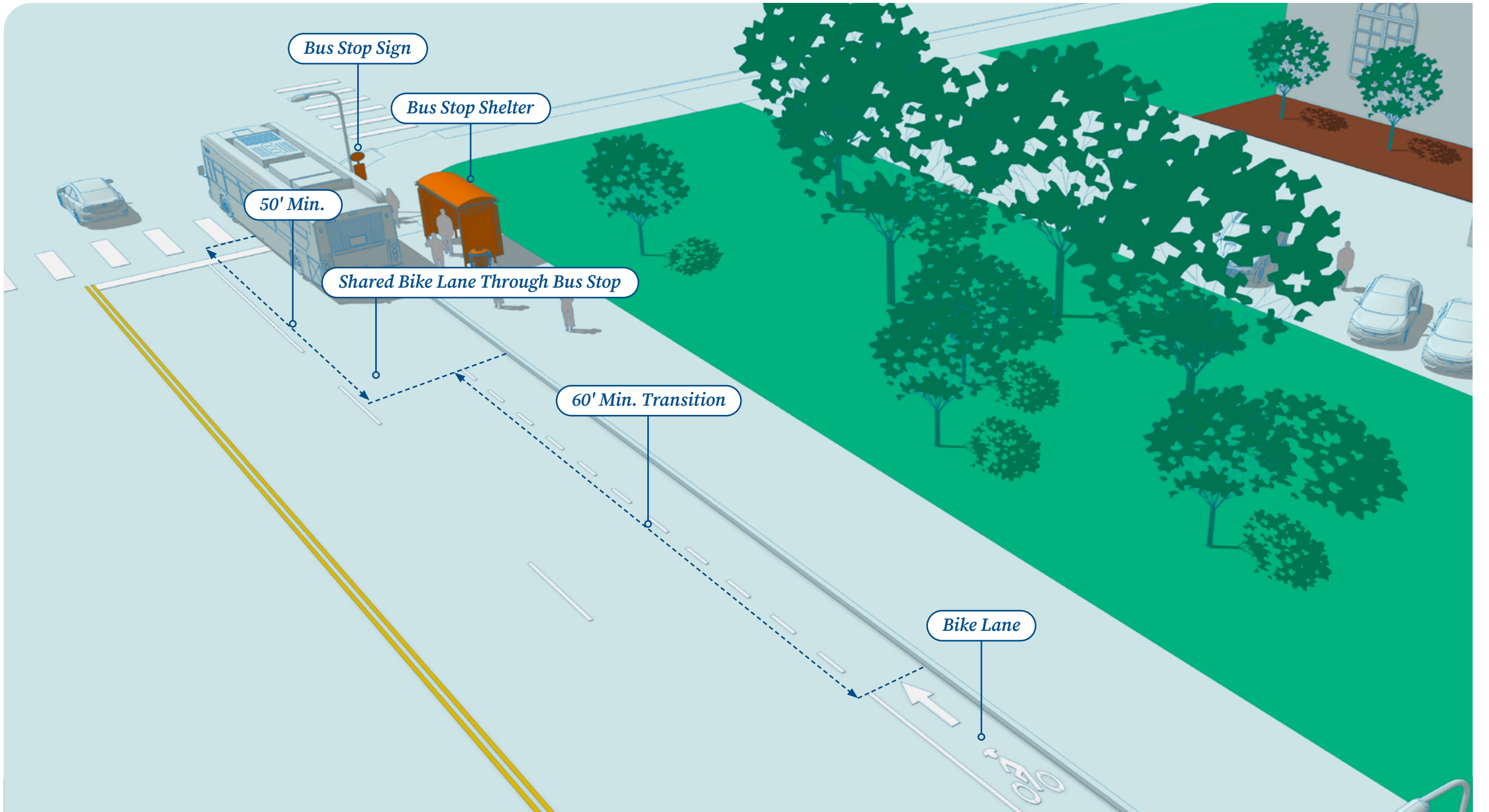

Near Side Bus Stop with On-Street Bike Lane

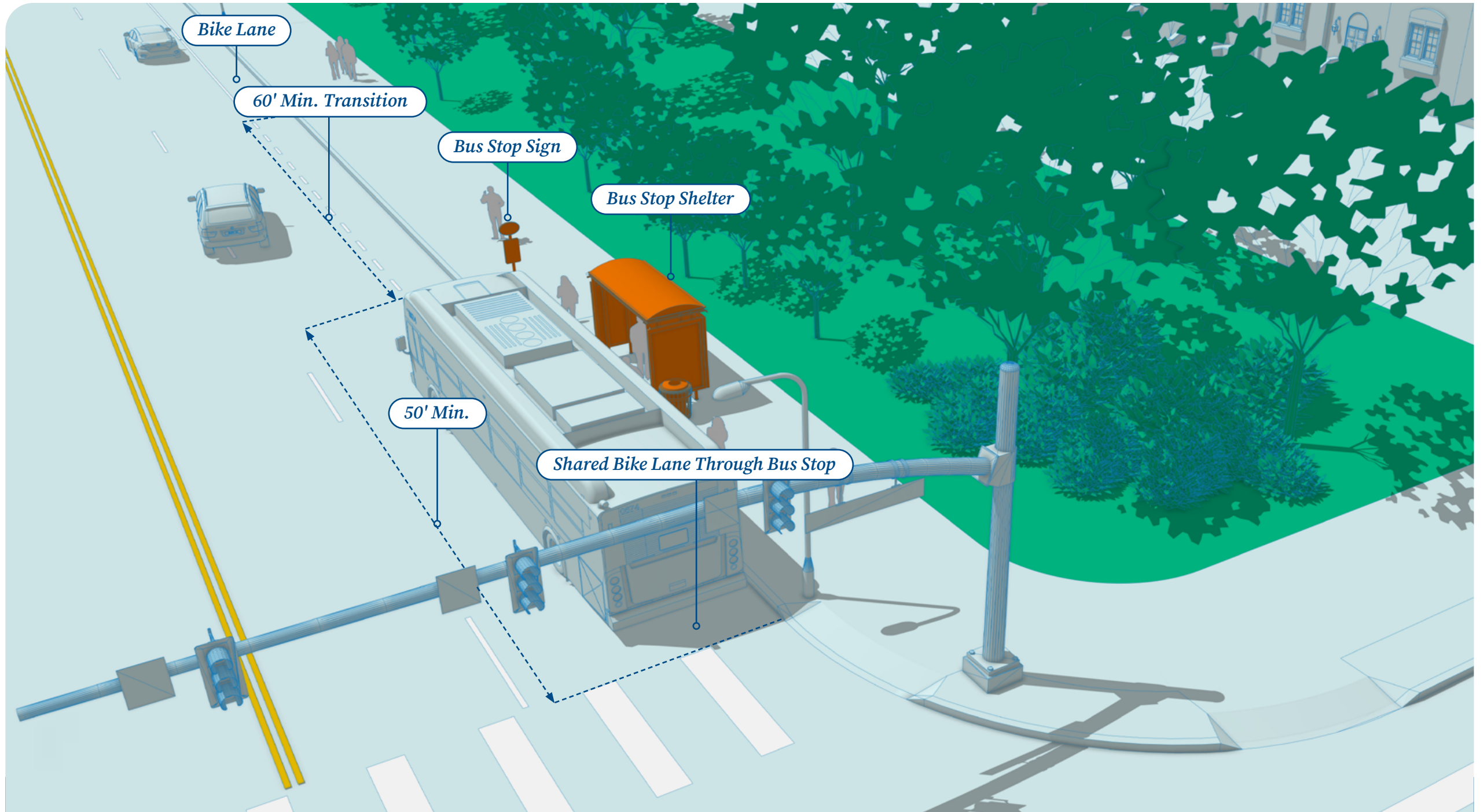

Far Side Bus Stop with On-Street Bike Lane